



Wireless Broadband Network Design Best Practices

Myths and Truths

Leonhard Korowajczuk
leonhard@celplan.com

CelPlan Technologies

- Provides Planning, Design and Optimization Software for all applications and network technologies
- Provides planning, design and optimization services
 - Has planned WiMAX and LTE networks worldwide
- Provides field measurements and RF propagation characterization
- Prepares RFPs, selects Vendors and Supports Deployments
- Provides High Level Consulting
- Provides Technology Training
- Provides Managed Services

Presenter

- **Leonhard Korowajczuk**

- CEO/CTO CelPlan Technologies
- 45 years of experience in the telecom field (R&D, manufacturing and services areas)
- Holds 13 patents
- Published books
 - “Designing cdma2000 Systems” published by Wiley in 2006- 963 pages, available in hard cover, e-book and Kindle
 - “LTE , WiMAX and WLAN Network Design, Optimization and Performance Analysis ” published by Wiley in June 2011- 750 pages, available in hard cover, e-book and Kindle
- Books in Preparation:
 - “LTE , WiMAX and WLAN Network Design, Optimization and Performance Analysis ”
 - second edition (2012) LTE-A and 802.16m (1,000+ pages)
 - Network Video: Private and Public Safety Applications (2013)
 - Backhaul Network Design (2013)
 - Multi-Technology Networks: from GSM to LTE (2013)
 - Smart Grids Network Design (2014)

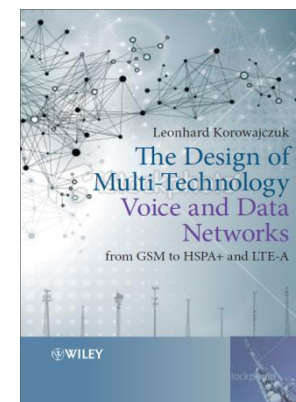
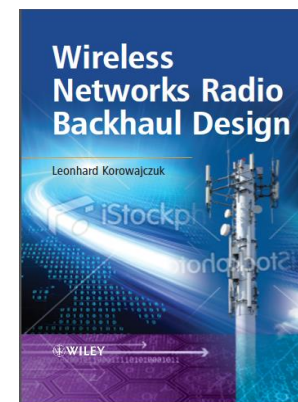
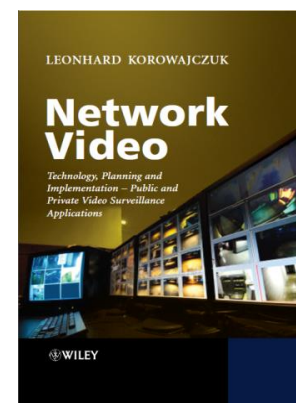
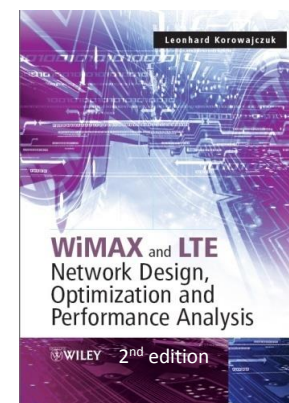
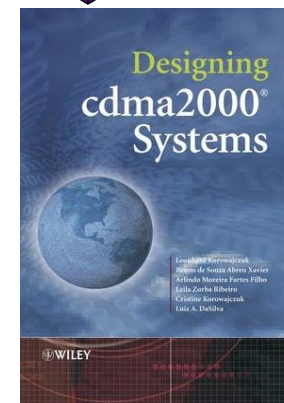
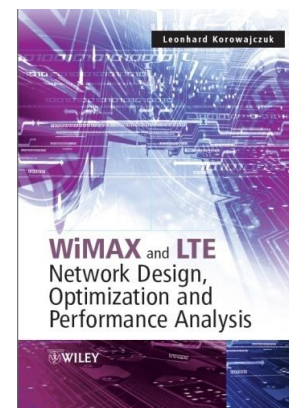

Myths

- You can use the same channel in all your cells (reuse of 1)



- You can have a throughput of 200 Mbps over a 10 MHz channel



- MIMO B (Spatial Multiplexing) will double or quadruple your throughput. You just need to add antennas.







- Your network was designed for a standard 3GPP environment, ETU30 (Extended Typical Urban model) and it will provide indoor coverage



- Link Budget : our equipment can provide indoor coverage at 10 km from the Base Station



Myths

- LTE provides a solution to the Peak to Average Ratio (PAPR) that affects WiMAX 
- LTE provides much more capacity than WiMAX 
- WiMAX UEs will be more expensive than LTE UEs 
- All operators have chosen LTE 
- My car was tested to do 10 km with less than 1 drop of gas
 - I omitted to tell that the test was done downhill 
- Some myths are repeated over and over until became virtual truths

Truths

- Specification Aspects
- Commercial Aspects
- Planning Aspects
- Technical Aspects
- Performance Aspects

Specification Aspects

Specification Aspects

- LTE has backtracked in many of its decisions about PAPR
 - SC-OFDM (Single Carrier OFDM) brought several disadvantages that out weighted the advantage
 - Release 10 allows for separated resource blocks, but keeps the shortcomings of SC-OFDM
- LTE does not have a solution for interference management
 - Issue was passed for vendors, resulting in incompatibility between systems
 - SON was offered as a future solution, but papers already indicate that a sound planning beats SON
 - LTE did not adopt permutation, segmentation or zoning used in WiMAX to control interference
 - Vendors are adopting it under the hood
- LTE specs are not compatible between versions
 - Release 8 UEs are not compatible with Release 8.2 UEs and so on
- WiMAX specifications are mature, LTE are still evolving (two to three years away)
- Both technologies do not specify schedulers and vendors are reluctant to share their implementations
 - Suggestion is to WiMAX Forum specify a scheduler

Commercial Aspects

Commercial Aspects

- Large operators have announced that they will deploy LTE
 - LTE is compatible in many aspects with existing 2G/3G infrastructure
 - *USIM compatibility is the main factor*
 - *Roaming is also a factor, but it has been prejudiced by the excessive band options* The plan was to leverage the GSM/UMTS infrastructure
 - In practice, little of existing infrastructure can be reused
 - Core prices are very high
 - Few did deploy until now
- WiMAX is being supported by
 - Medium and small operators
 - Overlay for large operators
 - Was adopted by the aeronautical industry as the next generation technology
 - Is being adopted by several Power grid operators
 - Is being adopted by the Oil and Gas industry
- **UE/CPE vendors announced that several of their units will be dual mode: WiMAX and LTE**
- WiMAX advantages
 - Lower equipment cost, commercially available infrastructure (IT based), provides larger vendor compatibility
 - Mature specification set, with vendor compatibility, through Plugfests
- LTE advantages
 - If adopted by major operators, will be a source of roaming revenue (restricted by band compatibility)

Planning Aspects

Planning Aspects Truths (Range)

- Link Budget magic: our equipment can provide indoor coverage at 10 km from the Base Station
 - Not really
 - Manipulating link budget parameters will not help in real life
 - Ignoring that the antenna gain is not uniform
 - Using Gaussian fading instead of Rayleigh fading
 - Increasing the FEC code to extremes like 1/12 will reduce throughput to a trickle
 - A 500 m to 1 km is a more realistic distance for indoor coverage

3GPP TR 3.913 v10.0.0

- The peak spectrum efficiency is the highest data rate normalised by overall cell bandwidth assuming error-free conditions, when all available radio resources for the corresponding link direction are assigned to a single UE.
- Average spectrum efficiency is defined as the aggregate throughput of all users (the number of correctly received bits over a certain period of time) normalized by the overall cell bandwidth divided by the number of cells. The average spectrum efficiency is measured in bps/Hz/cell
- The cell edge user throughput is defined as the 5% point of CDF of the user throughput normalized with the overall cell bandwidth. The calculations are done for 10 users randomly distributed.

LTE FDD ITU (Release 8) Spectral Efficiency Objectives (bit/s/Hz)

Scenario	Antennas	Cell Radius (m)	Path Loss (dB)	Downlink			Uplink		
				Peak (bps/Hz)	Average (bps/Hz/cell)	Cell Edge 10 users per cell (bps/Hz/cell/user)	Peak (bps/Hz)	Average (bps/Hz/cell)	Cell Edge 10 users per cell (bps/Hz/cell/user)
3GPP Case 1 Carrier: 2 GHz Bandwidth: 10 MHz	1x2	500	20				3.75	0.86	0.028
	2x2			7.5	1.63	0.05			
	4x2			15	1.93	0.06			
	4x4				2.87	0.11			

LTE-A ITU Spectral Efficiency Objectives (bit/s/Hz)

Scenario	Antennas	Cell Radius (m)	Path Loss (dB)	Downlink			Uplink		
				Peak (bps/Hz)	Average (bps/Hz/cell)	Cell Edge 10 users per cell (bps/Hz/cell/user)	Peak (bps/Hz)	Average (bps/Hz/cell)	Cell Edge 10 users per cell (bps/Hz/cell/user)
ITU Indoor Hot Spot	4x2	60			3	0.1		2.25	0.07
	2x4								
ITU Urban Micro	4x2	200			2.6	0.075		1.8	0.05
	2x4								
ITU Urban Macro	4x2	500			2.2	0.06		1.4	0.03
	2x4								
ITU Rural Macro	4x2	1732			1.1	0.04		0.7	0.015
	2x4								
3GPP Case 1 Carrier: 2 GHz Bandwidth: 10 MHz	1x2	500	20					1.2	0.04
	2x4							2	0.07
	2x2				2.4	0.07			
	4x2				2.6	0.09			
	4x4				3.7	0.12	15		
	8x8				30				

Planning Aspects

Adaptive Modulation Scheme

- You can have a throughput of 200 Mbps over a 10 MHz channel
 - Not really, even the 3GPP in its best estimates targets 4 bits/s/Hz
 - Real system do average less that 1 bit/s/Hz

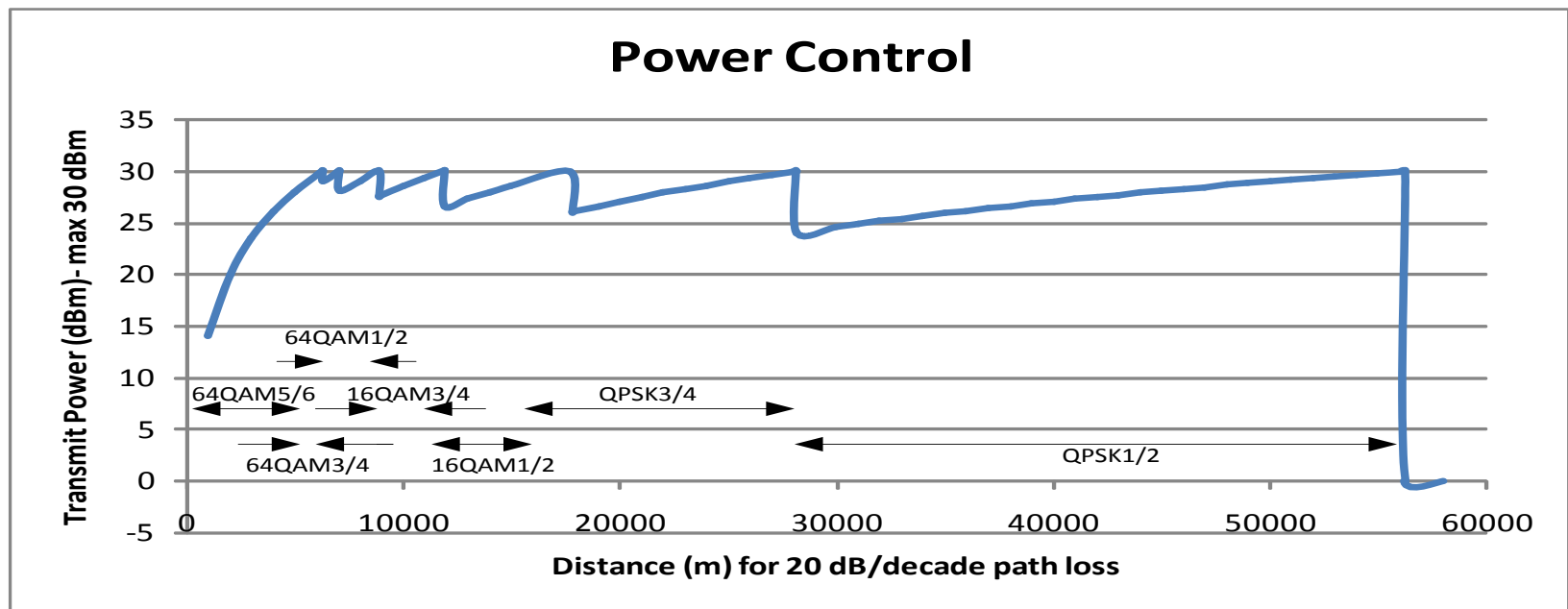

Adaptive Modulation Relative Areas

- Unrestricted cell
- Propagation in free space: 20dB/decade
- Percentages will change if cells are closer to each other and lower modulation schemes are not used
- Cell capacity drops with the increase in cell size

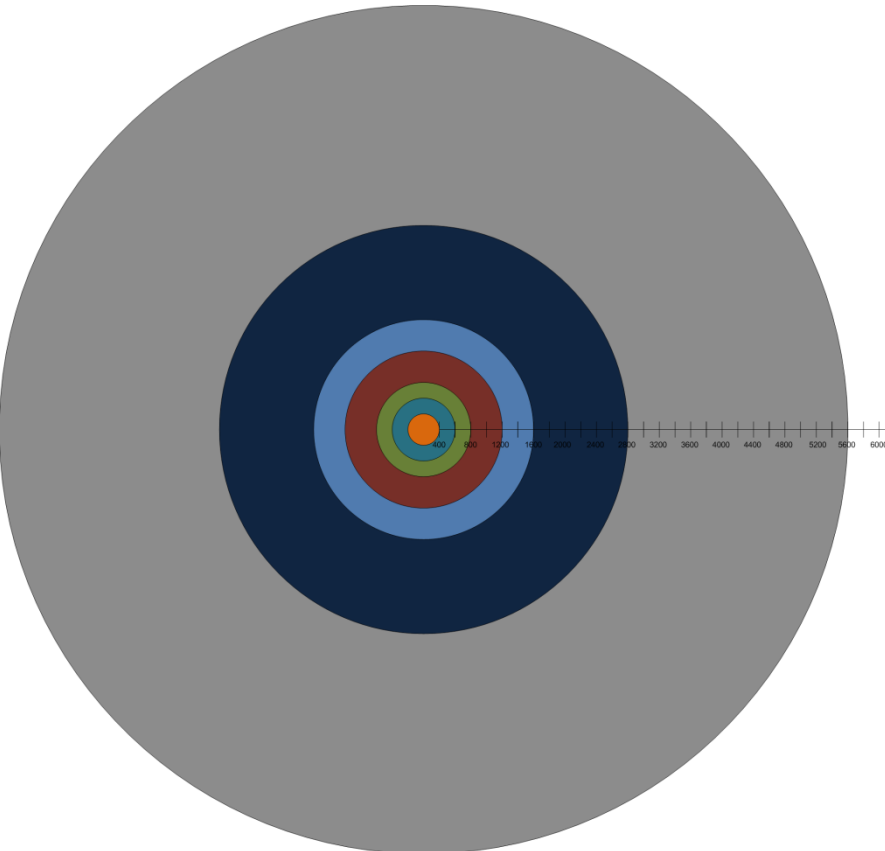

Bits / Symbol			
64QAM 5/6	5	0.5%	64QAM 5/6 (0.4 km ²)
64QAM 3/4	4.5	0.6%	64QAM 3/4 (0.6 km ²)
64QAM 1/2	3	0.9%	64QAM 1/2 (0.8 km ²)
16QAM 3/4	3	2.6%	16QAM 3/4 (1.2 km ²)
16QAM 1/2	2	3.6%	16QAM 1/2 (1.6 km ²)
QPSK 3/4	1.5	16.8%	QPSK 3/4 (2.8 km ²)
QPSK 1/2	1.5	75%	QPSK 1/2 (5.6 km ²)

Adaptive Modulation Capacity

- Bandwidth: 10 MHz
- Frame: 10 ms
- Cyclic Prefix: 1/8

Capacity per Modulation Scheme Coverage Limit

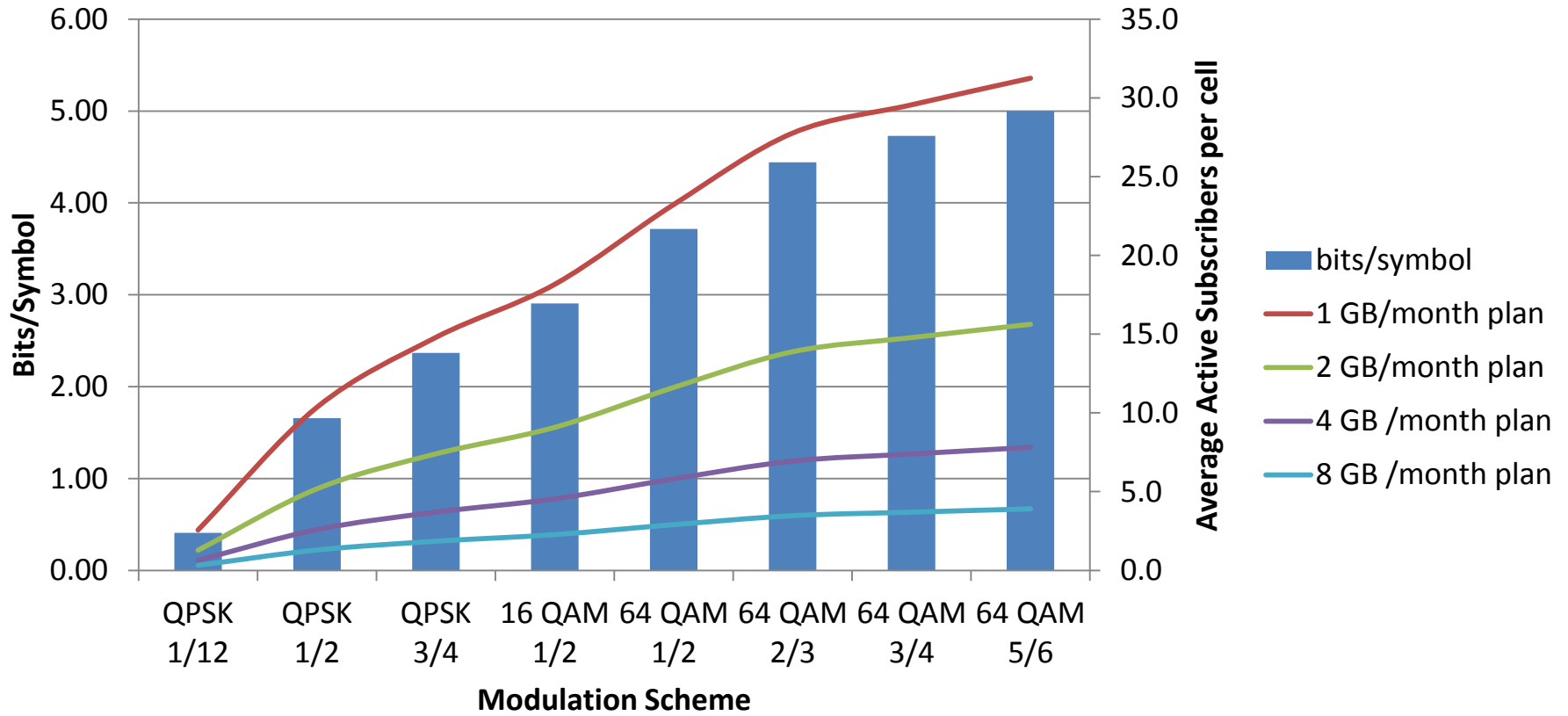

Planning Aspects Truths (Capacity)

- You can use the same channel in all your cells (reuse of 1)
 - Yes, you can, but the channels should be very lightly loaded
 - The rule of a minimum reuse of nine holds
 - Reuse applies to the following resources:
 - Frequencies
 - Sub-carriers
 - Time Slots
 - This means that the maximum cell load should be around 10%, considering all the resources
- Interference Averaging
 - WiMAX supports several standardized permutation schemes (PUSC, FUSC, AMC..)
 - LTE does not support permutation schemes and relies on vendor defined SON
 - Some vendors are using WiMAX permutation as a SON solution

Planning Aspects Truths (Capacity)

- Resource Reuse Factor
 - 2G and 3G technologies use frequency (GSM) or codes (UMTS, CDMA) as shared resources
 - 4G technologies (WiMAX and LTE) use as shared resources:
 - Frequencies
 - Sub-carriers
 - Segments (not supported by LTE)
 - Time Slots
 - Zones (not supported by LTE)
 - Codes

LTE deployments

- Traditional cellular operators will use 3GPP defined Access and Core
- Greenfield and WiMAX operators that add LTE deployments plan to use WiMAX Core with LTE Access
 - Main reason is economical and performance

WiMAX TDD Frame

- Subcarrier spacing: 10.9375 kHz
- Frame Duration: 2.25, 4, 5, 8, 10, 12.5, 20 ms
- Downlink Sub-Frame duration: variable
- Segments: up to 66
- Zones: up to 5

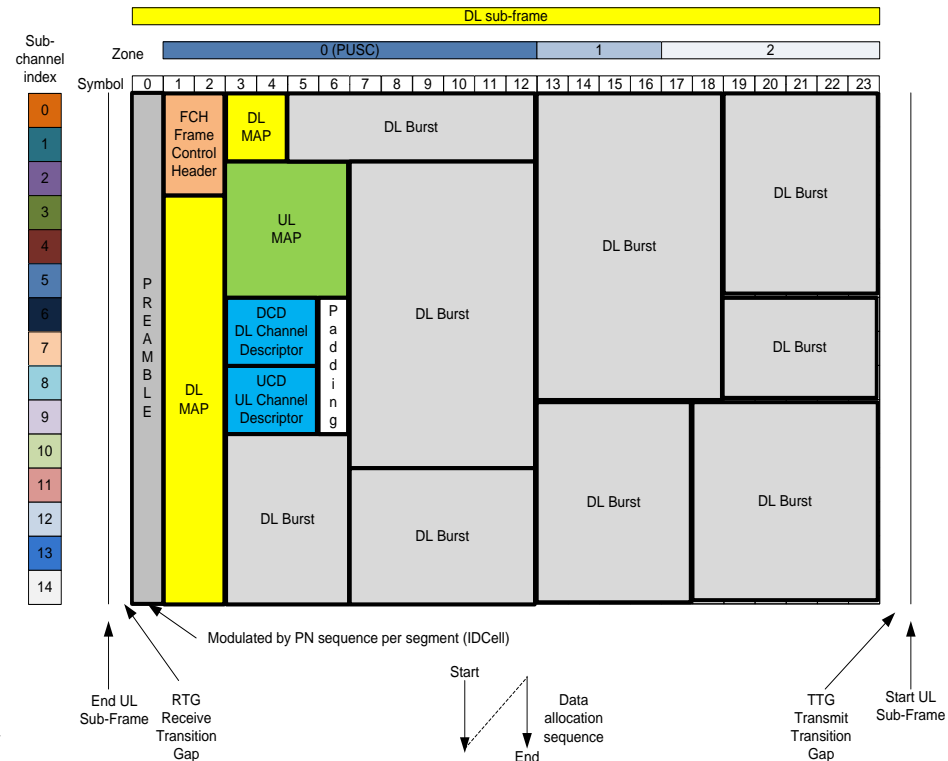
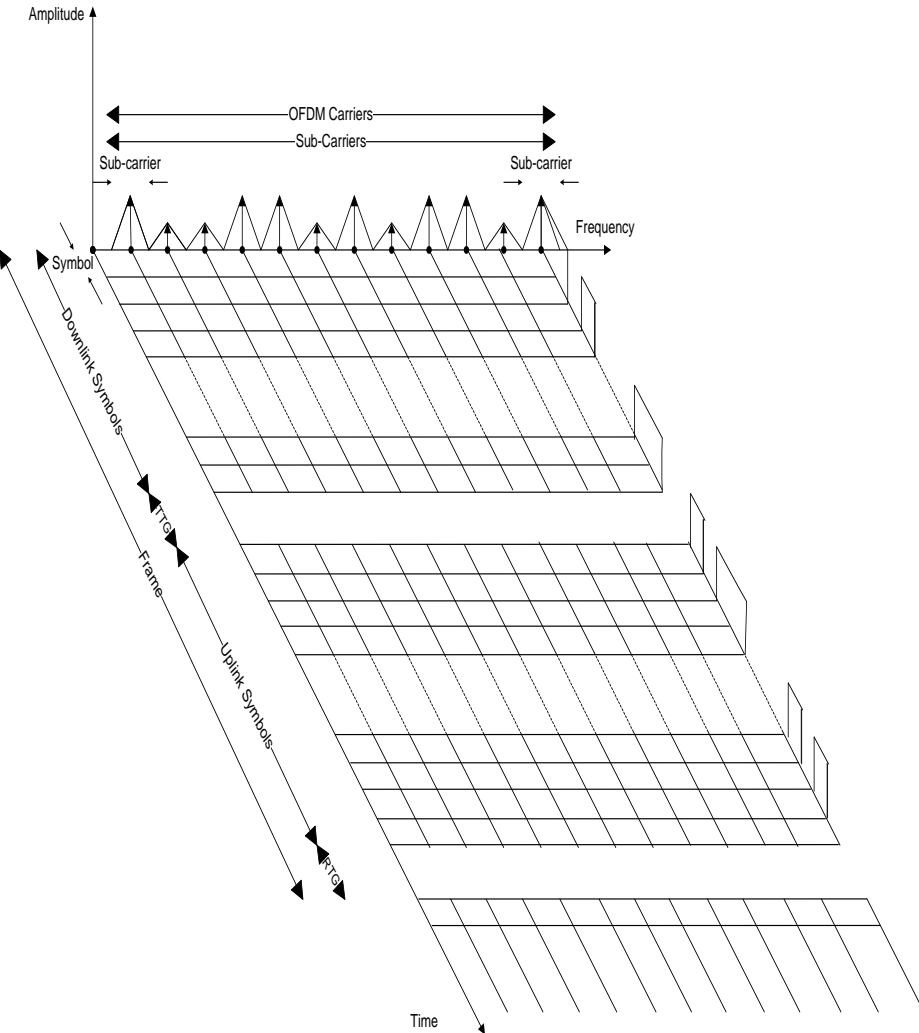

LTE Downlink Frame

Subcarrier spacing: 15 kHz

- Frame Duration: 10 ms
- Sub-Frame duration: 1ms
- Slot Duration: 0.5 ms
- Slot: 6 or 7 Symbols

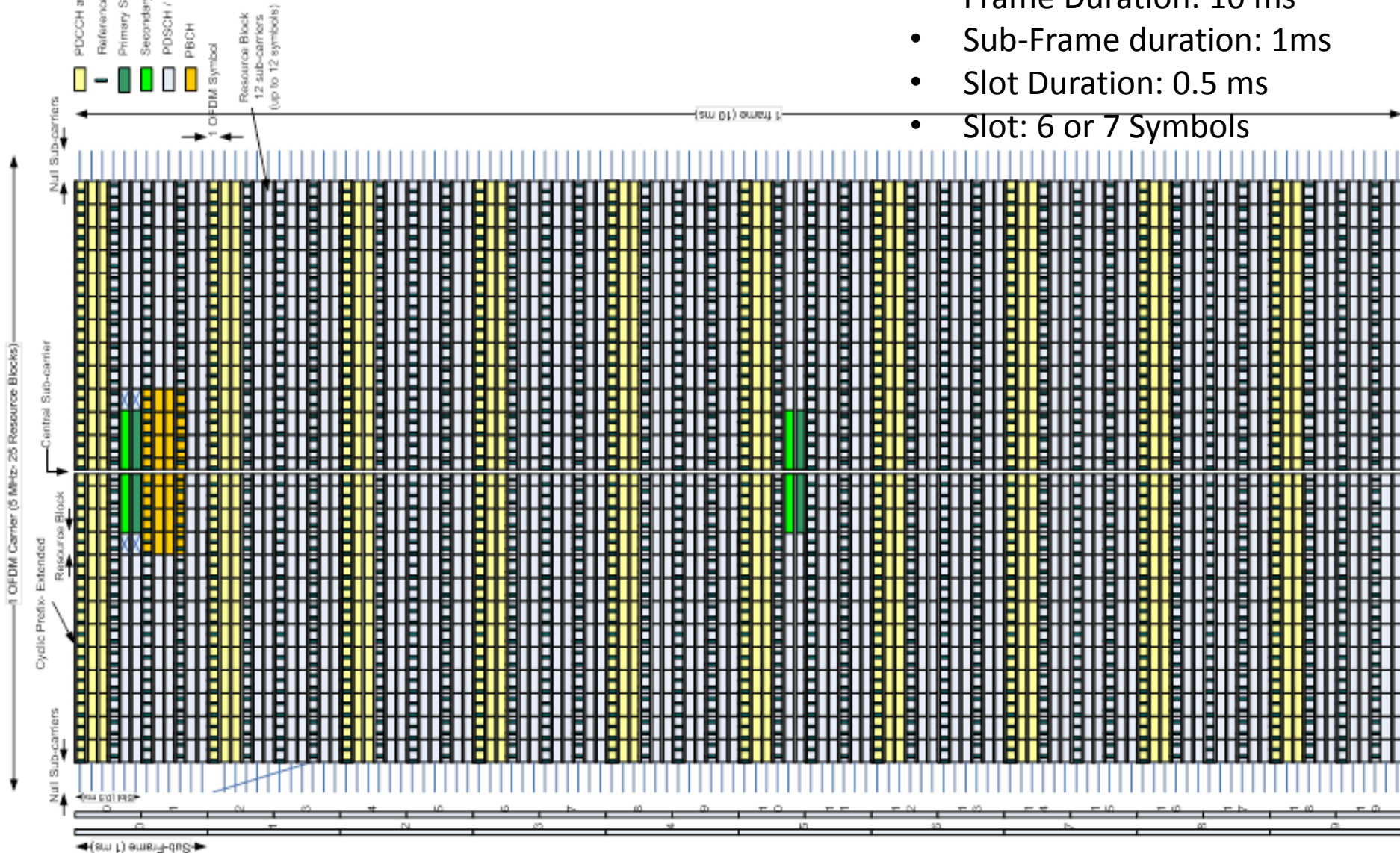

Performance Aspects

Performance Aspects

Comments about Data Speed and Throughput

Experiment

- I tested my Data Throughput and got 10 Mbit/s
- When reading my e-mails it took 20 second to open a 12.5 kB e-mail
- What is going on?
- At that speed it should take 10 ms
- The explanation is the difference between instantaneous and average throughput (Tonnage)

Instantaneous Throughput

- Wireless networks always send information at the maximum data rate possible
- This implies that high rates can be achieved
- It does not consider though the time the information has to wait to be scheduled
- Many networks slow down transmission based on the amount of data already transmitted by a user
- Speed test engines test the instantaneous throughput
- The instantaneous throughput gives only part of the information required to estimate the throughput

Tonnage

- Tonnage is the amount of data that is exchanged over a period of time by a user
- It takes into account waiting time and is a much better way to measuring the delivered service
- Network tonnage is defined by the average instantaneous throughput, which varies with the users location, due to the adaptive modulation
- User offered tonnage is defined by the application it uses, based on a ideal capacity network
- A single user's tonnage should be much smaller than the network tonnage, so the network could schedule several users to fill in its tonnage capacity
- This is called oversubscription ratio, which is expressed by the number of users sharing the same connection. It is equivalent to the telephony Erlang.
- The network should avoid load the available tonnage to 100%, as congestion will become an issue, as subscriber transmission times will coincide frequently
- A load of 60% to 70% should be targeted
- Tonnage can also be expressed in average bit/s (averaged over a period of several minutes to 1 hour)

3GPP TR 3.913 v10.0.0

- The peak spectrum efficiency is the highest data rate normalised by overall cell bandwidth assuming error-free conditions, when all available radio resources for the corresponding link direction are assigned to a single UE.
- Average spectrum efficiency is defined as the aggregate throughput of all users (the number of correctly received bits over a certain period of time) normalized by the overall cell bandwidth divided by the number of cells. The average spectrum efficiency is measured in bps/Hz/cell
- The cell edge user throughput is defined as the 5% point of CDF of the user throughput normalized with the overall cell bandwidth. The calculations are done for 10 users randomly distributed.

LTE FDD ITU (Release 8) Spectral Efficiency Objectives (bit/s/Hz)

Scenario	Antennas	Cell Radius (m)	Path Loss (dB)	Downlink			Uplink		
				Peak (bps/Hz)	Average (bps/Hz/cell)	Cell Edge 10 users per cell (bps/Hz/cell/user)	Peak (bps/Hz)	Average (bps/Hz/cell)	Cell Edge 10 users per cell (bps/Hz/cell/user)
3GPP Case 1 Carrier: 2 GHz Bandwidth: 10 MHz	1x2	500	20				3.75	0.86	0.028
	2x2			7.5	1.63	0.05			
	4x2			15	1.93	0.06			
	4x4				2.87	0.11			

LTE-A ITU Spectral Efficiency Objectives (bit/s/Hz)

Scenario	Antennas	Cell Radius (m)	Path Loss (dB)	Downlink			Uplink		
				Peak (bps/Hz)	Average (bps/Hz/cell)	Cell Edge 10 users per cell (bps/Hz/cell/user)	Peak (bps/Hz)	Average (bps/Hz/cell)	Cell Edge 10 users per cell (bps/Hz/cell/user)
ITU Indoor Hot Spot	4x2	60			3	0.1		2.25	0.07
	2x4								
ITU Urban Micro	4x2	200			2.6	0.075		1.8	0.05
	2x4								
ITU Urban Macro	4x2	500			2.2	0.06		1.4	0.03
	2x4								
ITU Rural Macro	4x2	1732			1.1	0.04		0.7	0.015
	2x4								
3GPP Case 1 Carrier: 2 GHz Bandwidth: 10 MHz	1x2	500	20					1.2	0.04
	2x4							2	0.07
	2x2				2.4	0.07			
	4x2				2.6	0.09			
	4x4				3.7	0.12	15		
	8x8				30				

Technical Aspects

Truths about MIMO

- A MIMO 4 x 4 can improve your SNR by 20 dB (using an USB)
 - MIMO Transmit Diversity can only reducing fading. It does not provide gain.
 - MIMO Spatial Multiplexing has the potential to double the throughput, but the streams interfere with each other, so practical throughput increase is 20% or less
 - MIMO requires uncorrelated antennas, but this is difficult to achieve
 - Increasing the number of antennas only makes it more difficult to un-correlate them

Truths about MIMO

- MIMO B will double or quadruple your throughput
 - MIMO Spatial Multiplexing has the potential to double the throughput, but the streams interfere with each other, so practical throughput increase is 20% or less
 - MIMO requires uncorrelated antennas, but this is difficult to achieve
 - Increasing the number of antennas only makes it more difficult to un-correlate them

Performance Aspects

RF Channel Response, Fading and Antenna Correlation

Questions that do not have replies today

- What is network's RF channel response?
 - How wide and long is the multipath fading?
 - How many multipath are being received?
- How un-correlated are cell antennas?
 - How to adjust the antennas for maximum un-correlation?
- What is the channel load and how are the resources distributed?
- How should the network parameters be optimized?

CelSDRx™

- Universal Software Defined Receiver (SDRx)
- Captures up to 100 MHz of spectrum from 100 MHz to 18 GHz
- Digitizes signal at 125 Msps and provides I and Q components
- Digitally extracts information for any digital technology: LTE, WiMAX, HSPA, UMTS, GSM
- Performs
 - Symbol synchronization
 - Frame Synchronization
 - Sub-Channel Equalization
 - Bandwidth and frame number determination
- Detects
 - RF Channel Response in time and frequency
 - Displays fading amplitude, band and duration
 - Channel Traffic load
 - Received signal coherence from different antennas
 - Received signal coherence to different antennas
- GPS data geo-referencing, allowing drive tests
- Ideal to plan network parameters
- Ideal to scan competitive networks
- Patents applied



CelSDRx™ Specifications

- Frequency coverage: 100 MHz to 18 GHz
- Instantaneous Bandwidth: 100 MHz
- Displayed Average Noise Level:
 - -115 dBm @ 10 MHz
 - -110 dBm @ 1500 MHz
 - -110 dBm @ 2500 MHz
- Maximum RF input: +10 dBm
- Non-input related spurs: < -100 dBm
- Maximum RF gain: 20 dB
- IF gain: -10 to +30 dB in 1 dB steps
- Power Supply +12 VDC

Impulse Response

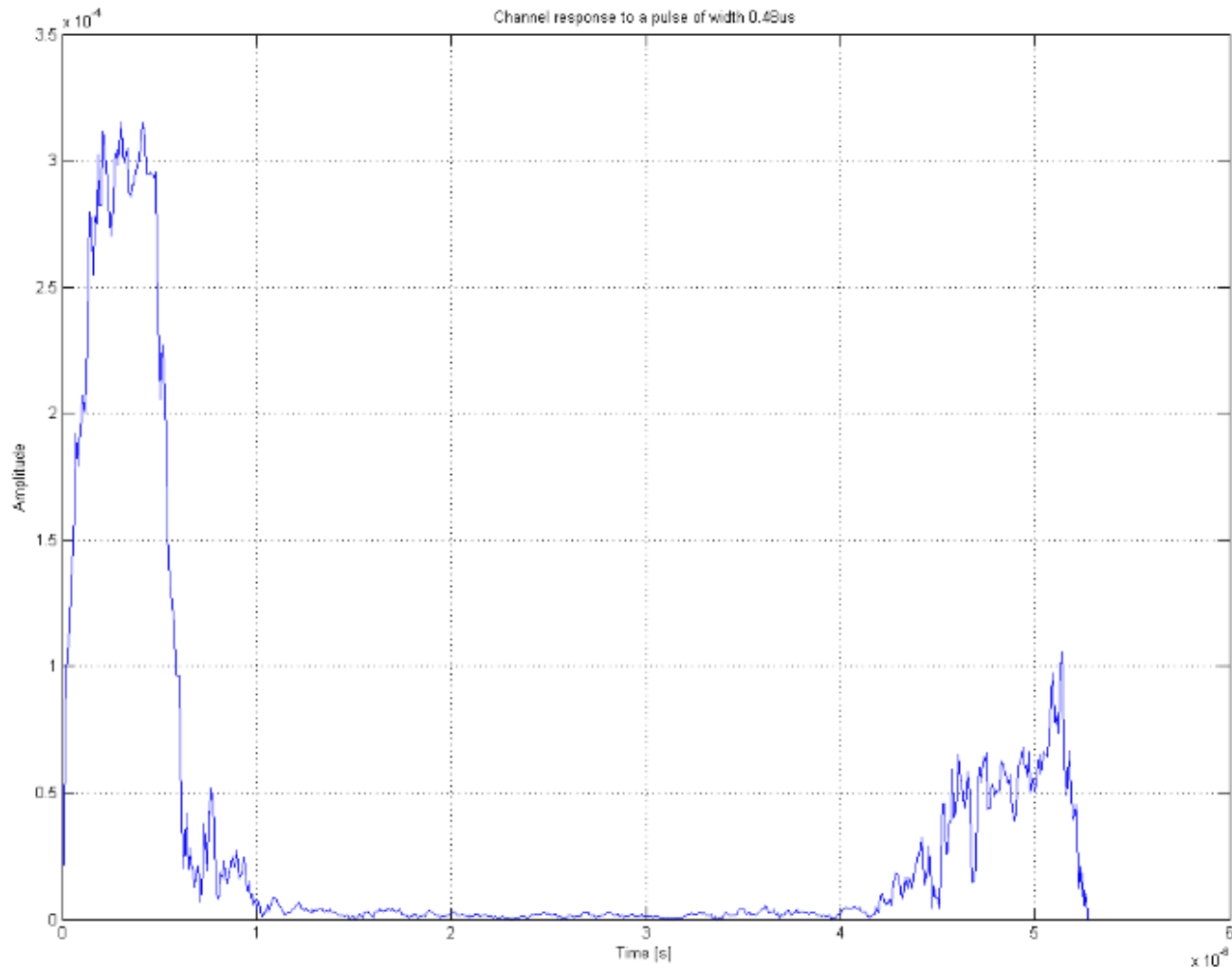

Measured Power per Resource Element (dBm)

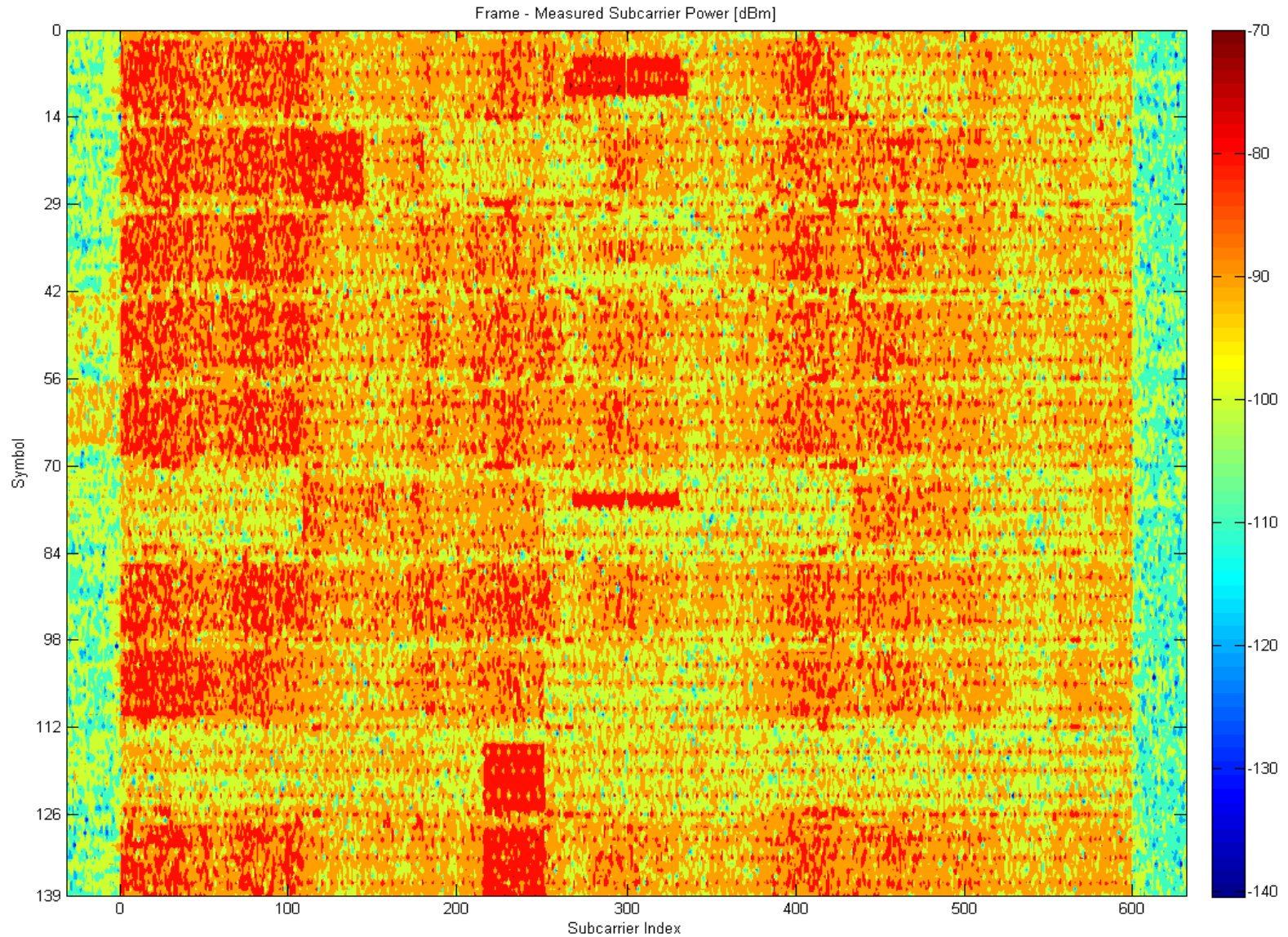

RF Channel Response (top view)

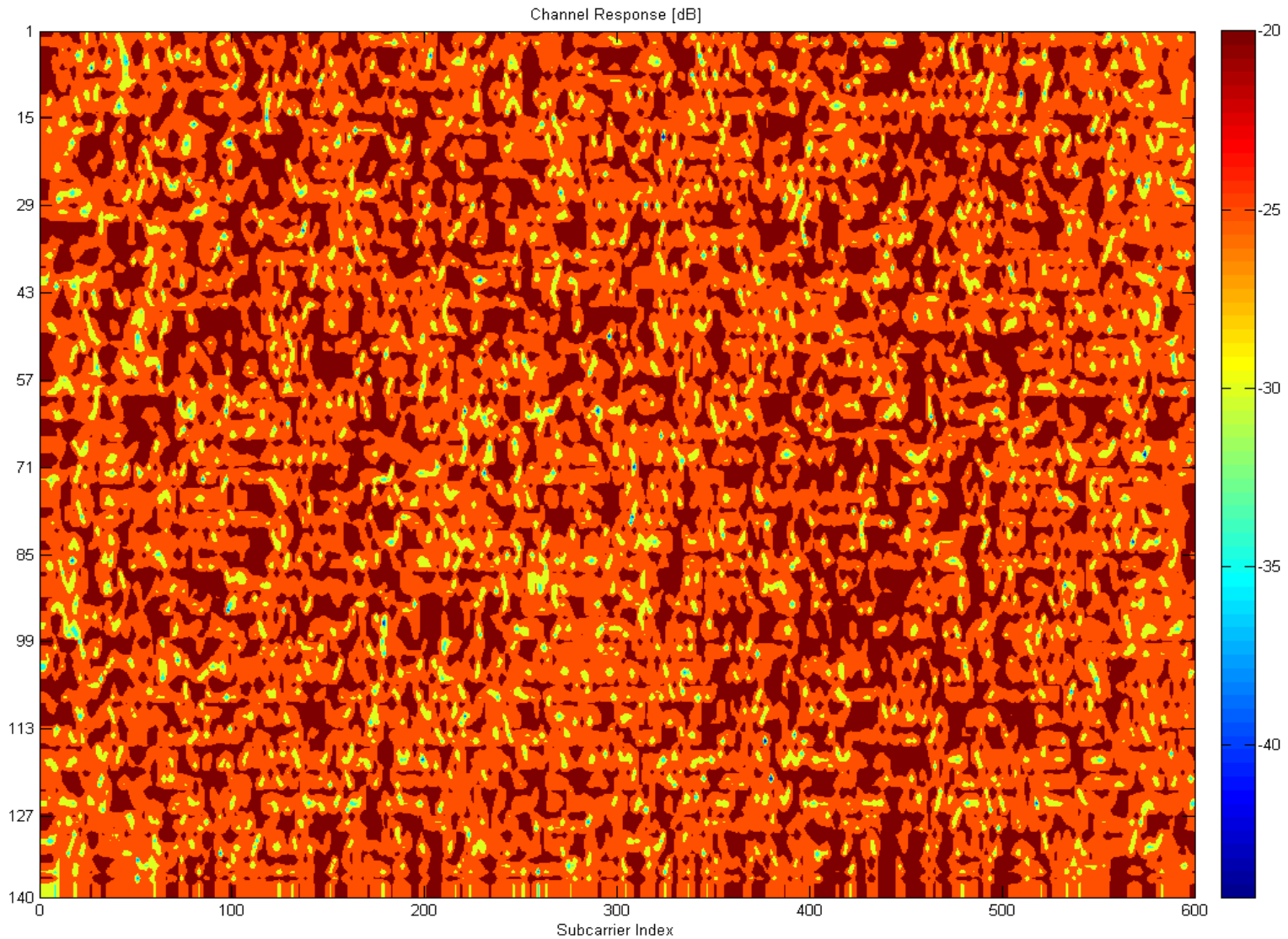

RF Channel Response (time zoom)

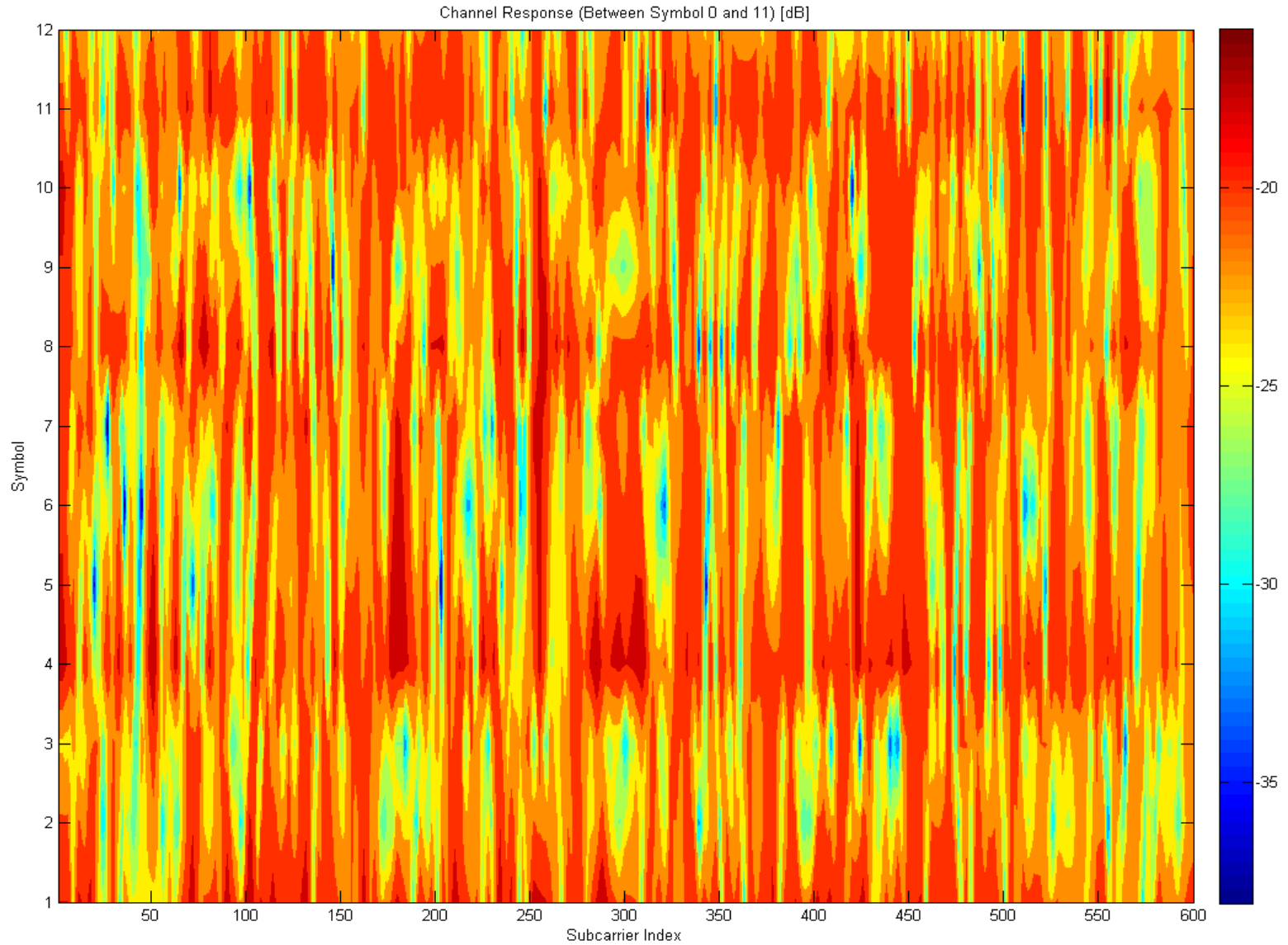

RF Channel Response (3D detail)

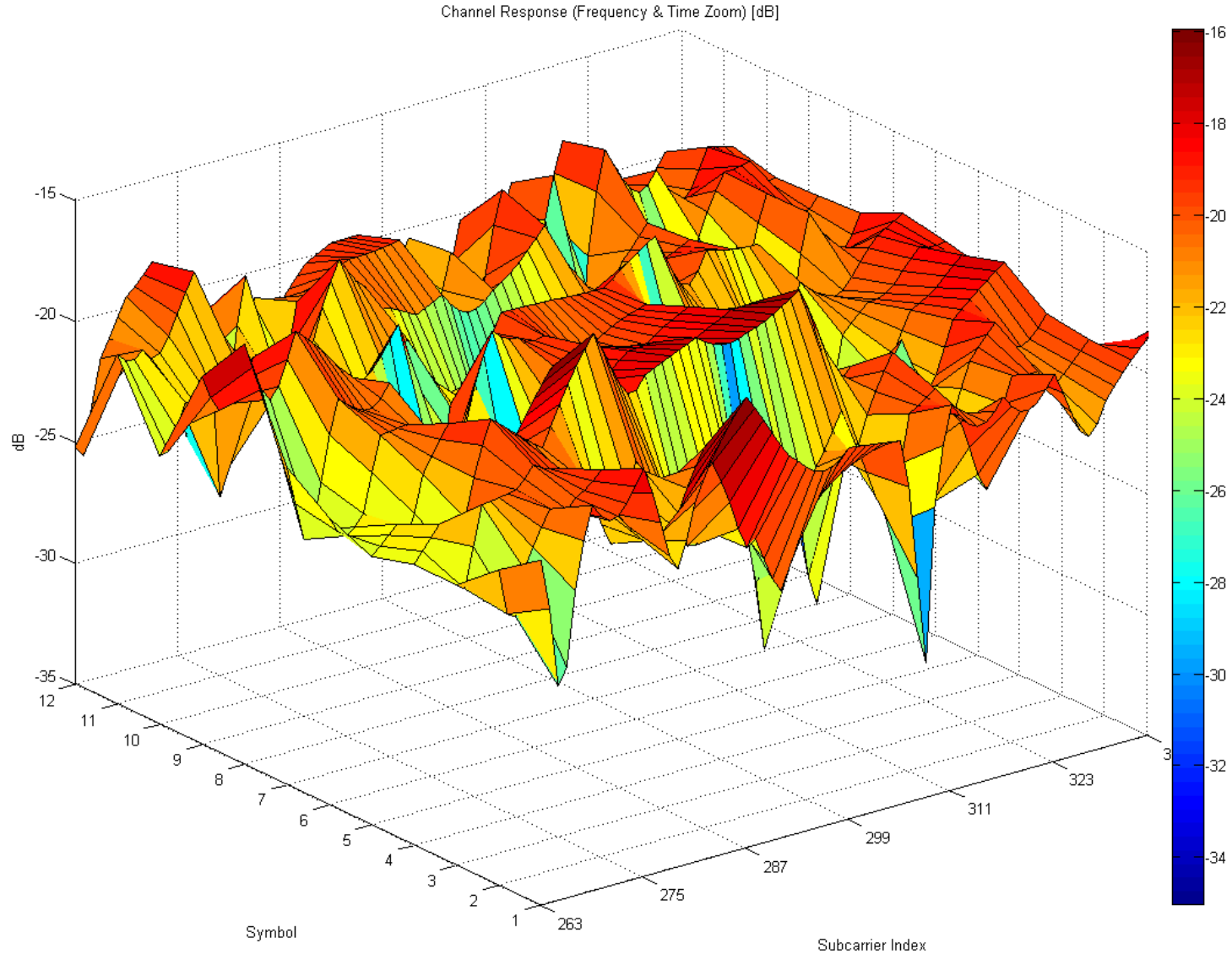

Adjusted Power per Resource Element (dBm)

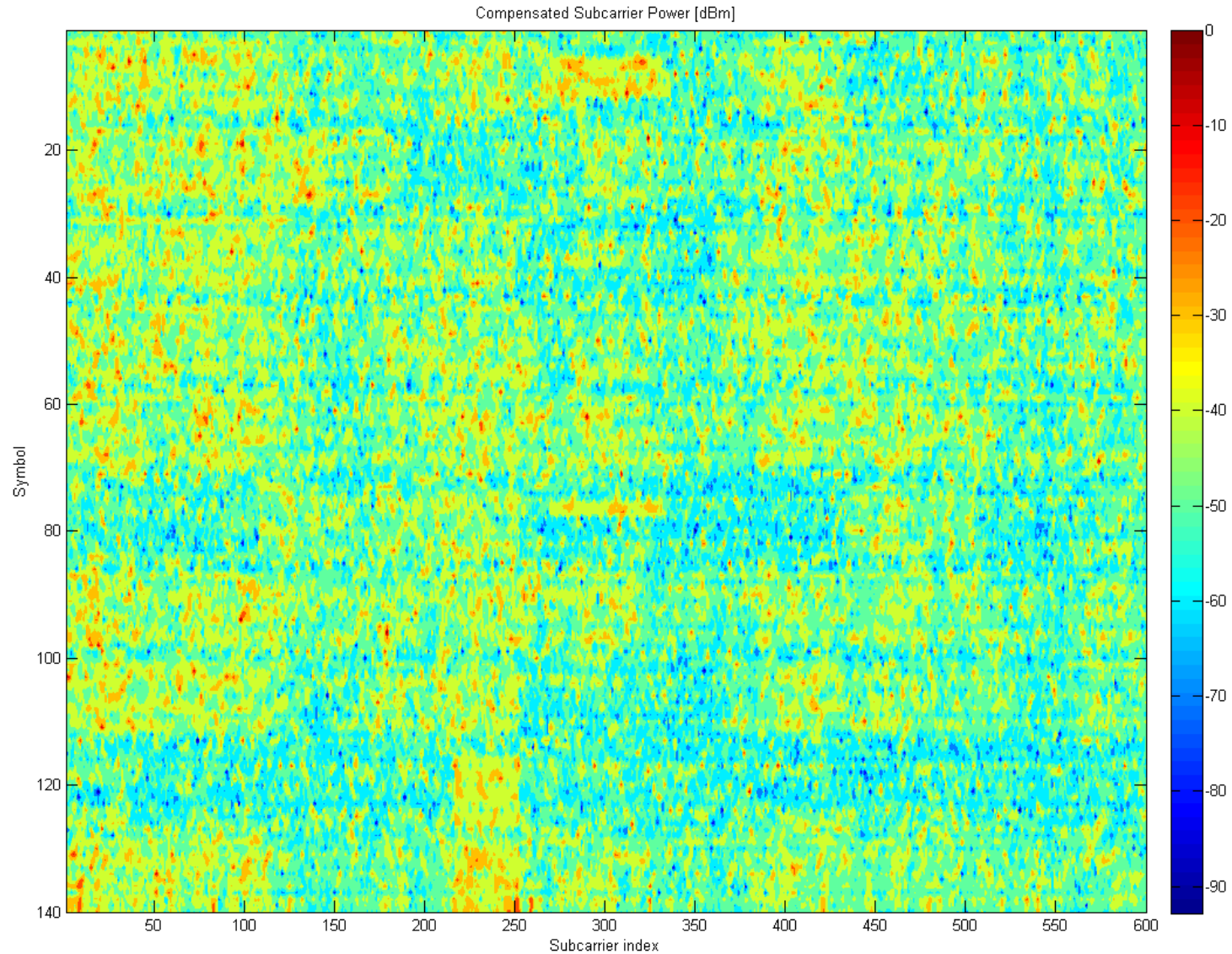

Traffic view

- Traffic allocation can be visualized per frame

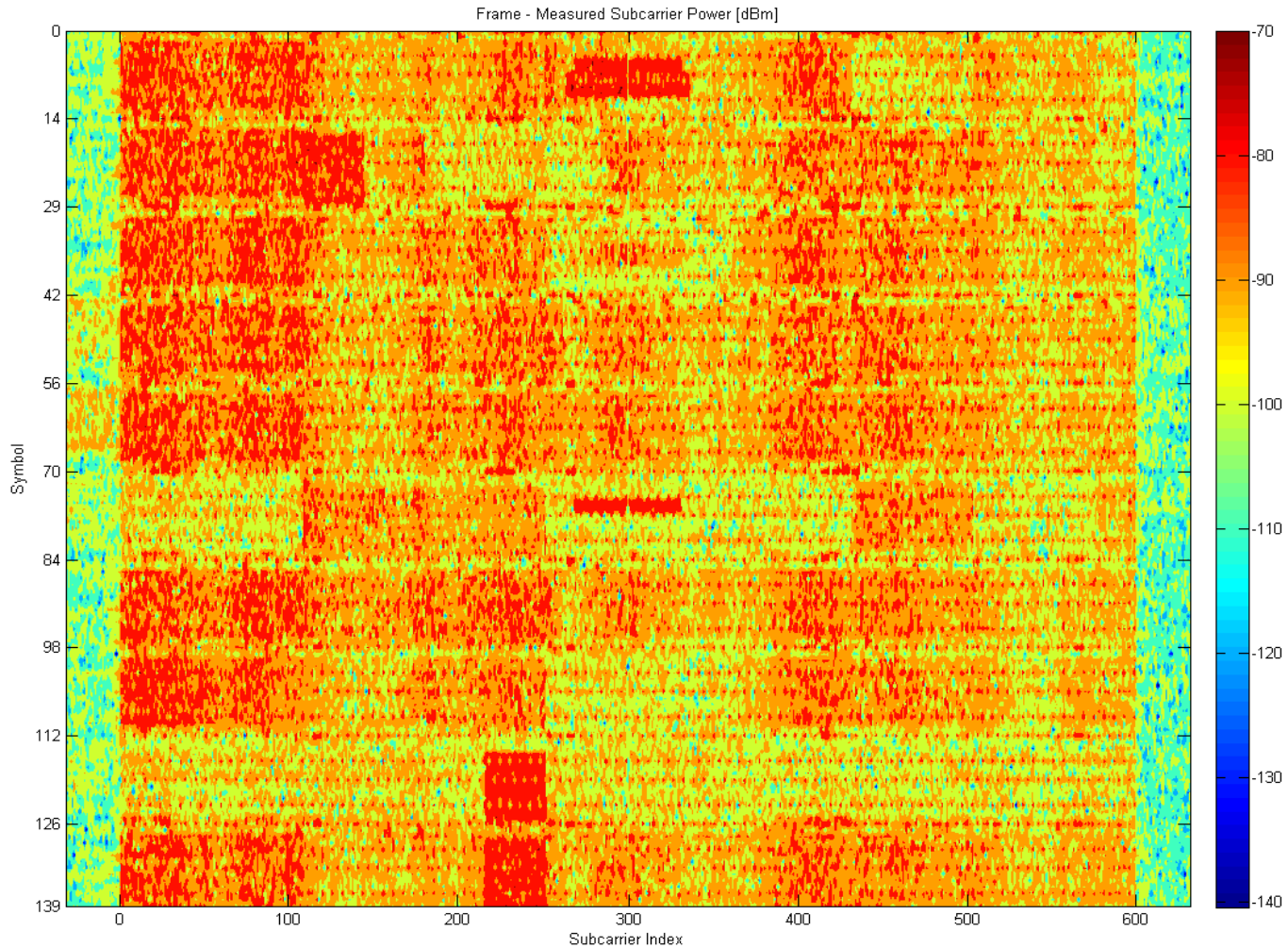

Correlation

- Correlation is considered as the sympathetic movement of two or more variables
- Pearson's Product-Moment Correlation Coefficient

$$r_{xy} = \frac{\sum_{i=1}^n (x_i - \bar{x})(y_i - \bar{y})}{(n-1)s_x s_y} = \frac{\sum_{i=1}^n (x_i - \bar{x})(y_i - \bar{y})}{\sqrt{\sum_{i=1}^n (x_i - \bar{x})^2 \sum_{i=1}^n (y_i - \bar{y})^2}}$$

- The correlation coefficient varies between +1 and -1
 - Positive Correlation: movement is in the same direction
 - Negative Correlation: movement is in the opposite direction
- Reference signals transmitted by two antennas can be used to establish the channel response
- The correlation coefficient for the two channel responses can then be calculated

Correlation between antennas

- Correlation index between two antennas
 $CI=0.42$

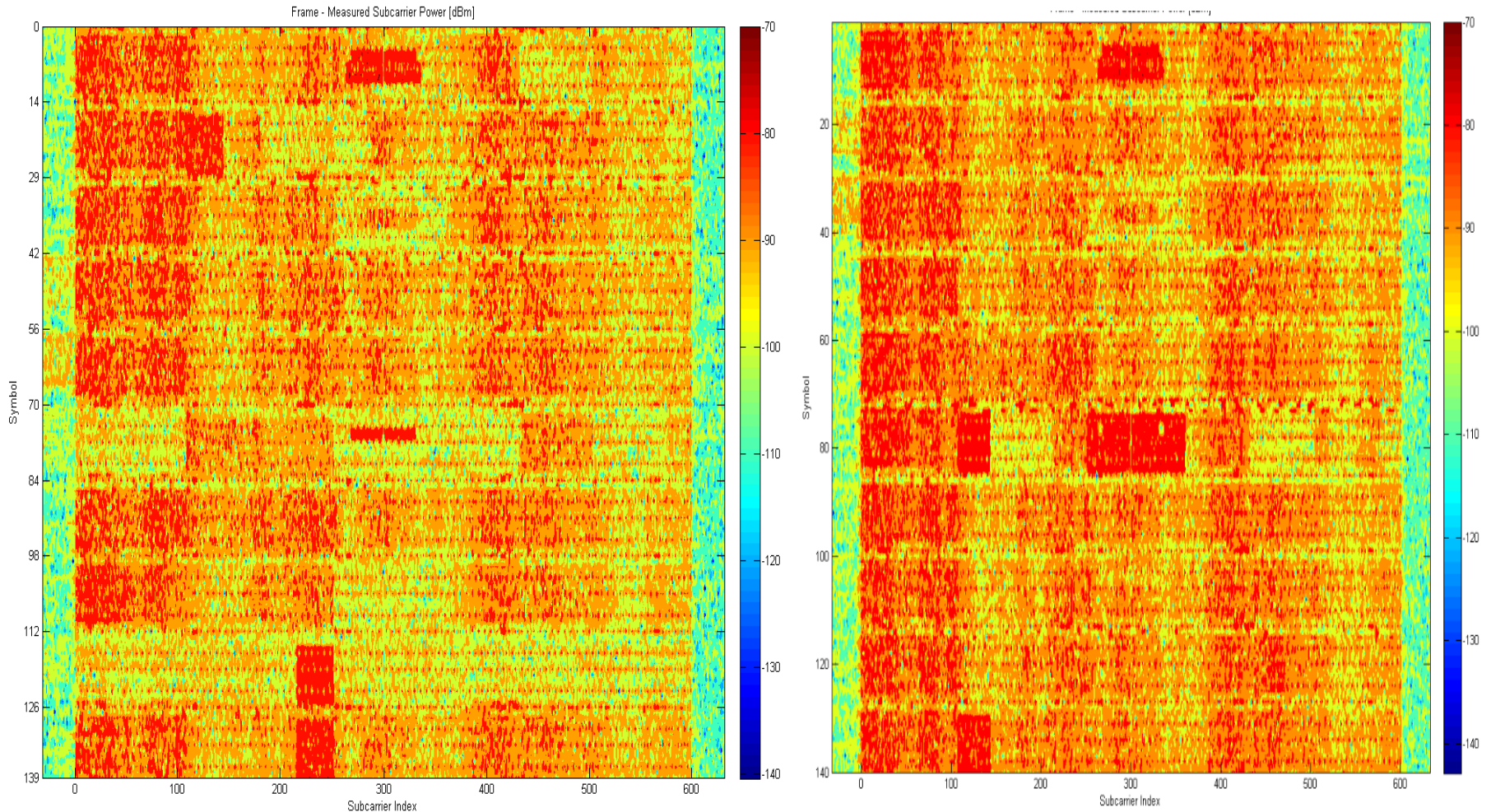

Antenna Correlation Drive

- Antenna correlation variation

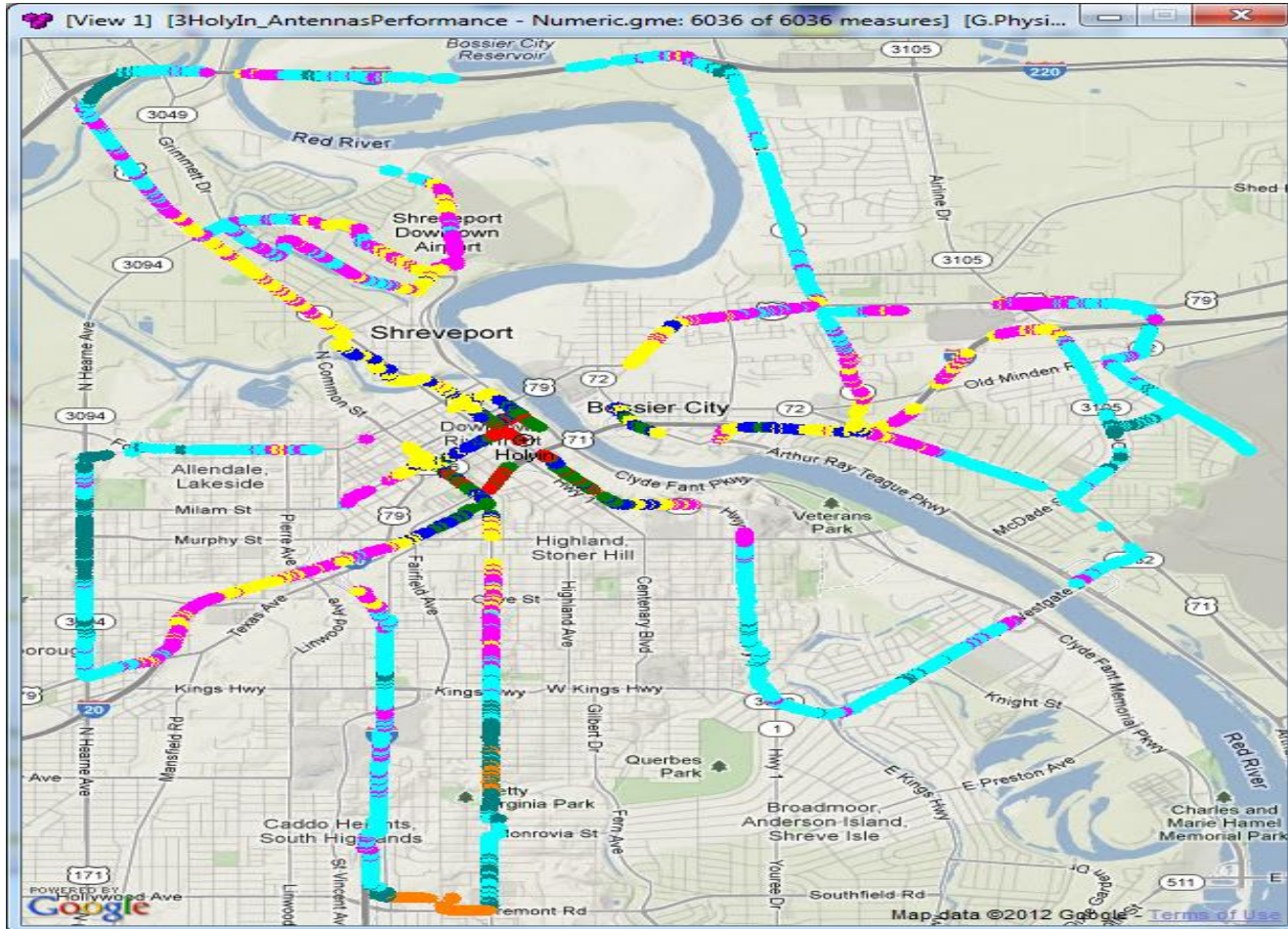

Antennas Performance	
Correlation - [View 1]	
■	C ≥ 0.75 (1.2%)
■	C ≥ 0.50 (3.5%)
■	C ≥ 0.25 (4.2%)
■	C ≥ 0.00 (16.1%)
■	C ≥ -0.25 (24.0%)
■	C ≥ -0.50 (42.3%)
■	C ≥ -1.00 (1.6%)

What is in a Link Budget?

A Link Budget accounts for the gains and losses between the transmitter and the receiver

What is in a Link Budget?

Power Budget and Noise Budget

- A link budget analyzes two paths
 - One is the power budget (in blue) from the Transmitter to the Receiver
 - Another is the noise budget (in green) from the Thermal Noise Floor to the CNIR ratio required for a certain receive probability
 - The difference between both budgets establishes the service margin

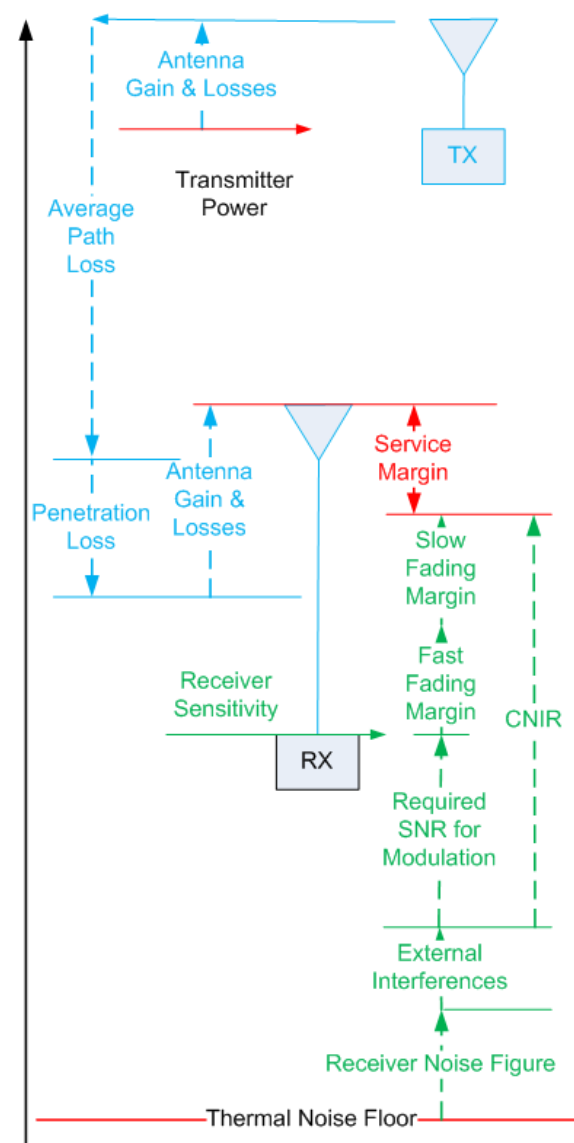

What is in a Link Budget?

Antenna Gains and Losses

- The transmit power is the power that comes from the Power Amplifier to each antenna
- The Antenna Gain should include all the losses (combiners, jumpers, connectors, cables)
- The antenna gain is at its maximum only in the azimuth direction
- The EIRP (Effective Isotropic Radiated Power) is the power that leaves the antenna

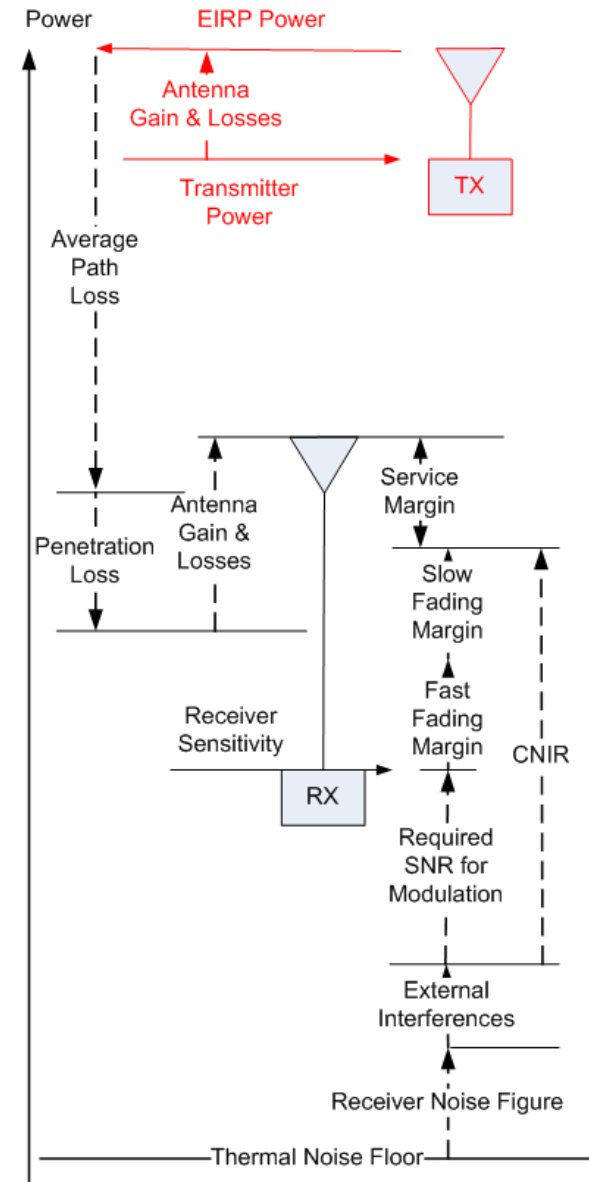
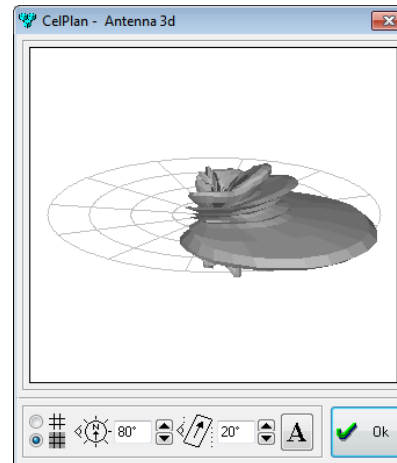
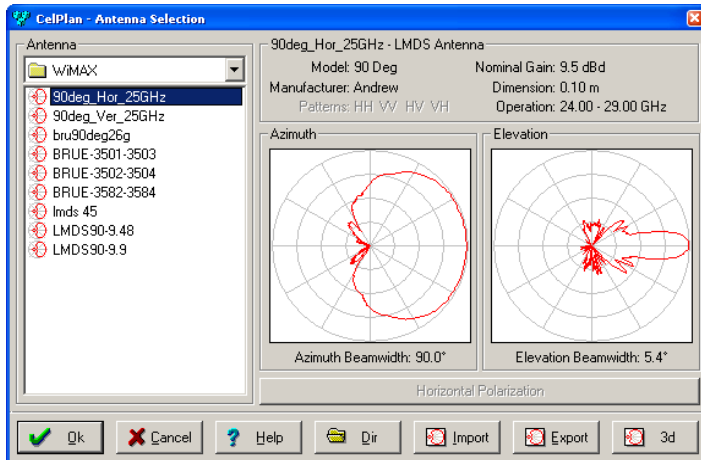

What is in a Link Budget?

Average Path Loss, Penetration Loss, Antenna Gain and Losses

- The **average path loss** is an average loss value between the antenna and the each prediction location (prediction pixel)
- The prediction pixel area is a rectangle with sides varying from 5 to 30 m
- The path loss considered at each pixel is the average over the pixel area over a period of time (blue line below)
- Path loss is predicted for outdoors so, for indoor predictions a **penetration loss** should be added
- **Receive antenna gain and losses** should be added
- The antenna gain is at its maximum only for the azimuth direction
- The resulting power level is what is offered to the receiver

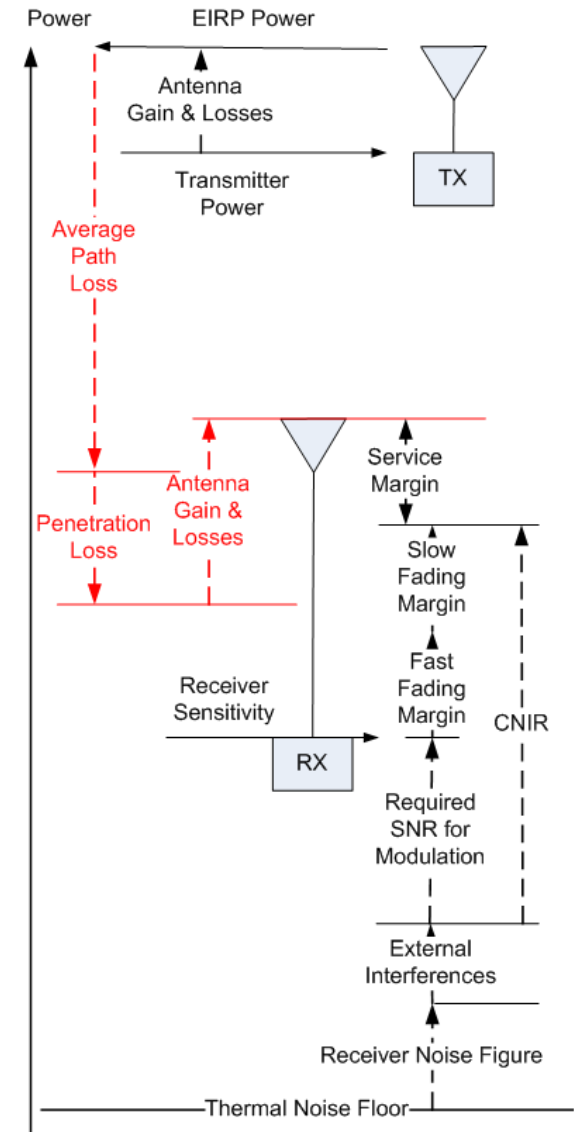
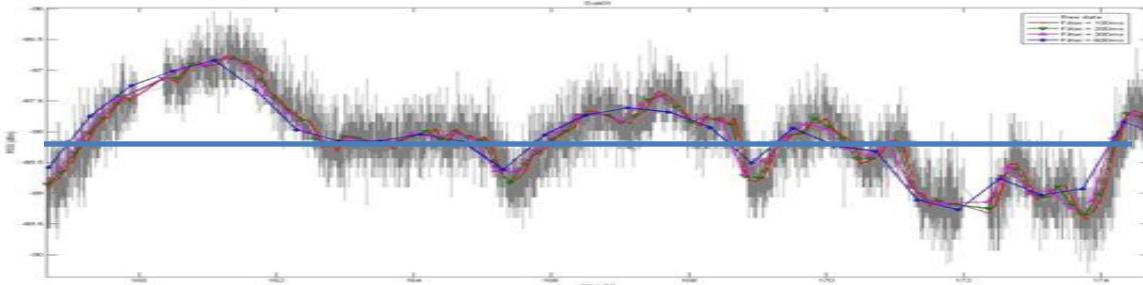

What is in a Link Budget?

Thermal Noise Floor

- A Thermal Noise Floor exists everywhere due to molecular movement, and it is based on the ambient temperature
 - This noise floor is -174 dBm/Hz at 25°C
 - Noise for other bandwidths is shown below

Bandwidth (Hz)	RF Noise (dBm)
1	-174
10	-164
100	-154
1 K	-144
10K	-134
30K	-129
100 K	-124
200K	-121
1M	-114
1.5M	-112
5M	-107
10 M	-104
20 M	-101
40M	-98

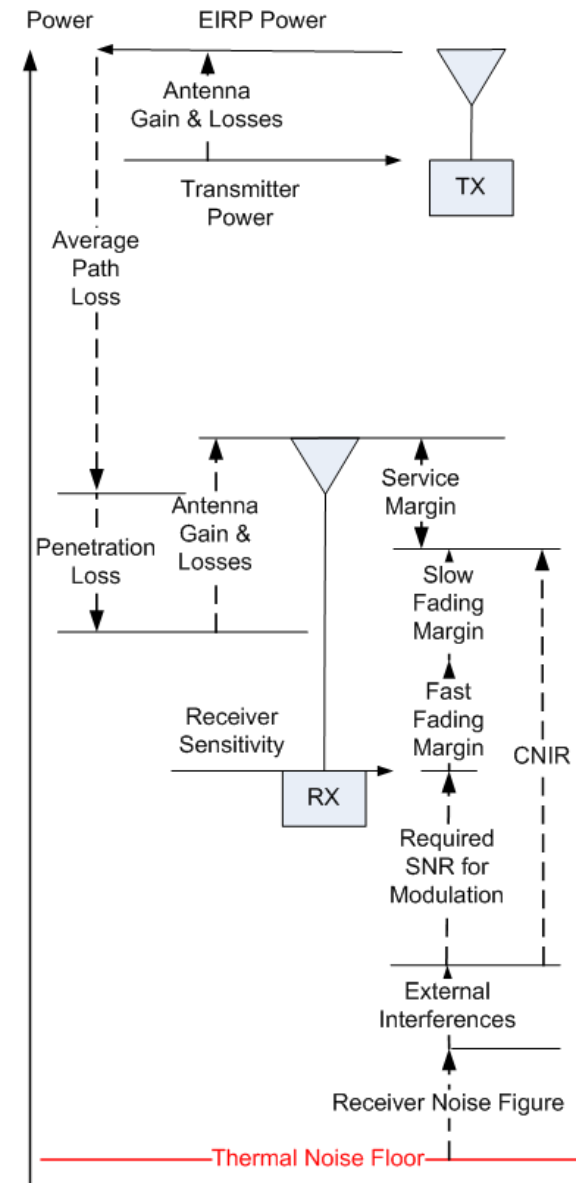

What is in a Link Budget?

Receiver Noise Figure and External interference (Noise Rise)

- The **Receiver Noise Figure** is the noise caused by the receiver components themselves
- The first receiver amplifier plays an important role in determining the noise figure
- Typical Noise Figures (NF) are:
 - Tower mounted LNA: 2 to 3 dB
 - Base Station: 5 to 8 dB
 - Mobile: 8 to 12 dB
- **External Interferences**
 - Interferences add to noise floor
 - Interference sources are:
 - Neighbor own cells
 - Neighbor systems cells
 - Other devices (microwave oven)
 - Man made noise
 - Interference noise is also called **Noise Rise**
 - Typical figures are between 2 and 8 dB

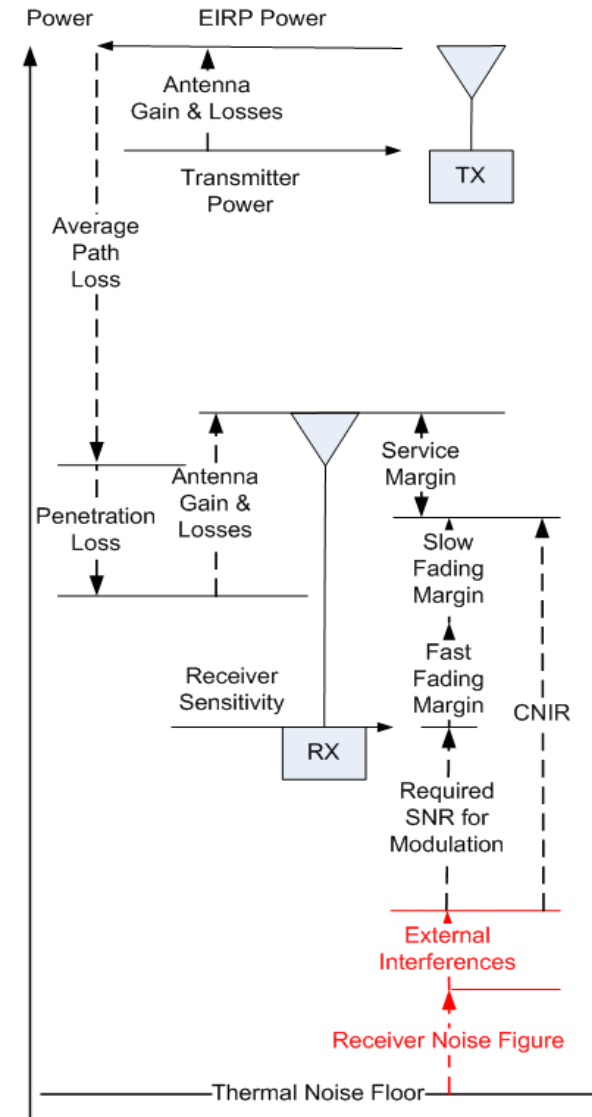

What is in a Link Budget?

Required SNR Ratio per Modulation

- Modulation
 - Is the act of adding information to a carrier
 - This is done by changing the carrier amplitude and phase
 - Each combination of amplitude and phase defines a carrier state
 - Each carrier state is produced by a combination of a cosine and a sine of the carrier frequency
 - Sine and cosine are orthogonal to each other (can be detected separately when combined)
 - The cosine component is called I (in-phase) and the sine component Q (in quadrature, meaning 90° out of phase)

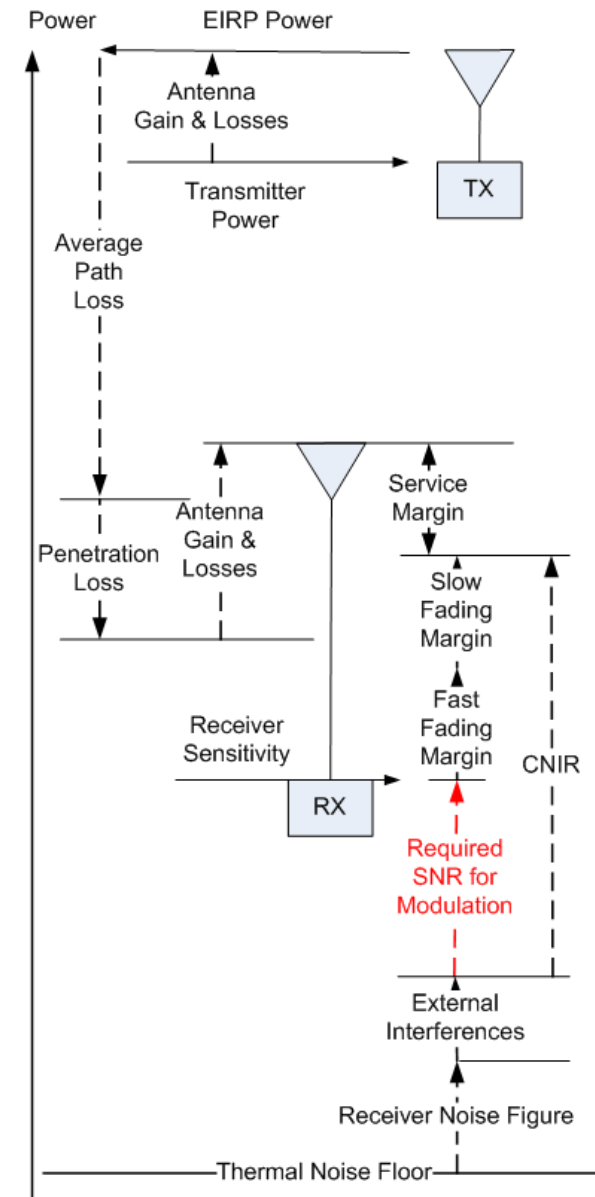

What is in a Link Budget? Required SNR Ratio per Modulation

- Modulation Constellation
 - Only one state can be transmitted at a time
 - Each constellation state is assigned a symbol
 - The number of bits assigned to a symbol is proportional to the number of modulation states (see table below)
 - The intersymbol distance defines the maximum SNR (Signal to Noise Ratio) that will result in a specified error rate
 - SNR is specified for error rates from 10^{-2} to 10^{-6}

BPSK

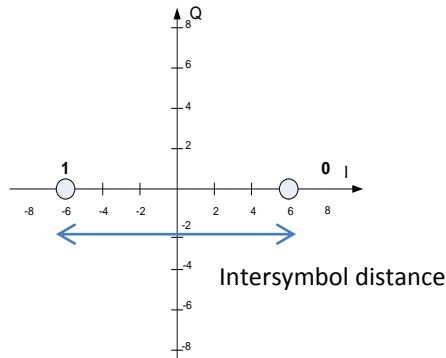

QPSK

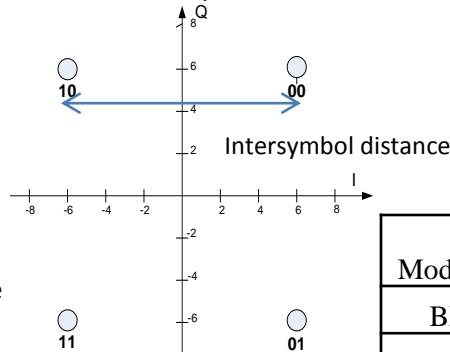

16 QAM

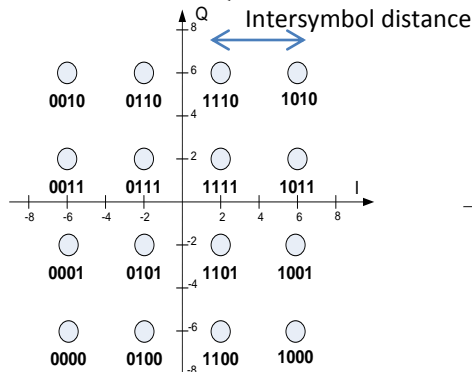

64QAM

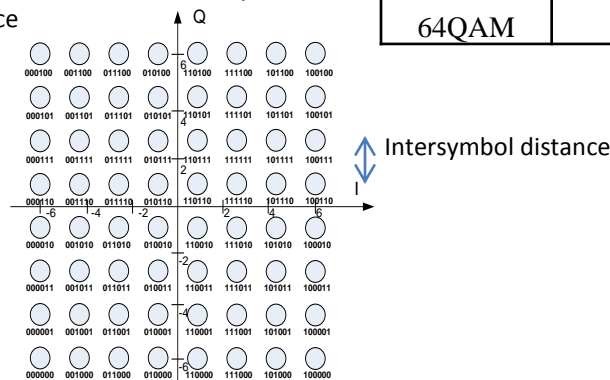

Modulation	Number of bits per symbol
BPSK	1
QPSK	2
16QAM	4
64QAM	6

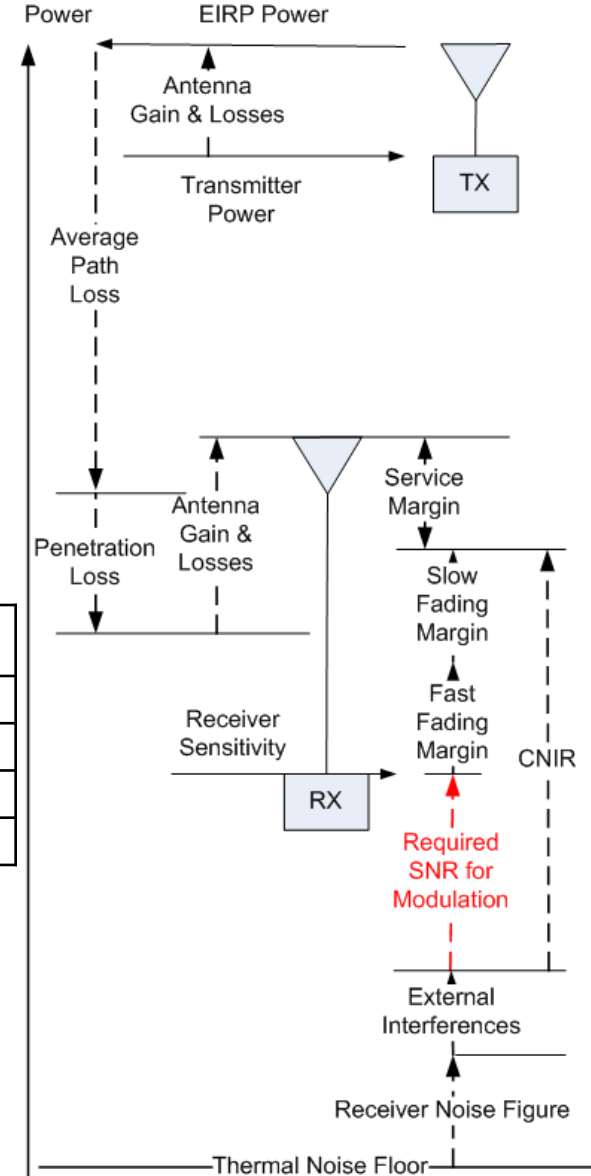

Required SNR Ratio per Modulation

What is in a Link Budget?

- Forward Error Correction
 - The error rate referred in the modulation is due to noise spikes
 - A huge SNR would be required to eliminate the errors, instead a error correcting code is added to fix the errors at the receiver
 - Correcting errors after they happen implies in retransmissions and consequently delays
 - Error correction codes are sent together with the data, so the majority of the errors can be corrected without retransmission
 - This is called Forward Error Correction (FEC)
 - Typical error correction codes are:
 - Convolutional codes
 - Turbo codes
 - A code ratio specifies the ratio between the number of data and the total number of transmitted symbols
 - Typical code ratios are: 1/2 (1 data and 1 error correction, 1/4 (1 data and 3 error correction), 5/6 (5 data and 1 error correction)....
 - The combination modulation and FEC code ratio is called modulation scheme
 - A Modulation scheme is the combination of the modulation type with the FEC code ratio used

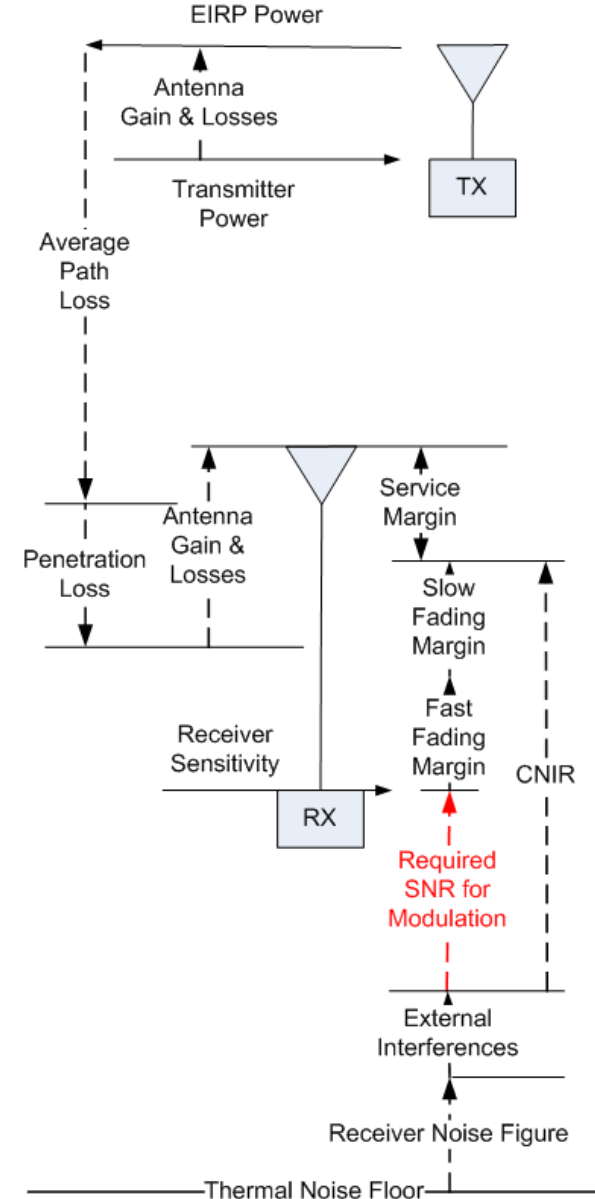

What is in a Link Budget?

Required SNR Ratio per Modulation

- Backward Error Correction
 - A FEC can not correct all errors, so Backward Correction Codes (BCC) are used to fix them, if the application requires them to be fixed
 - In a practical system there are several layers of BCC (typically 3 to 5)
 - The BCC codes are distributed at several protocol layers
 - Higher the protocol layer, longer it takes to correct the error, and consequently the latency increases
 - Some applications can not accept any errors (TCP-Transmission Control Protocol- based), while others can accept errors (UDP- User Datagram protocol-based)
 - Example: Web is TCP based, while U-tube is UDP based

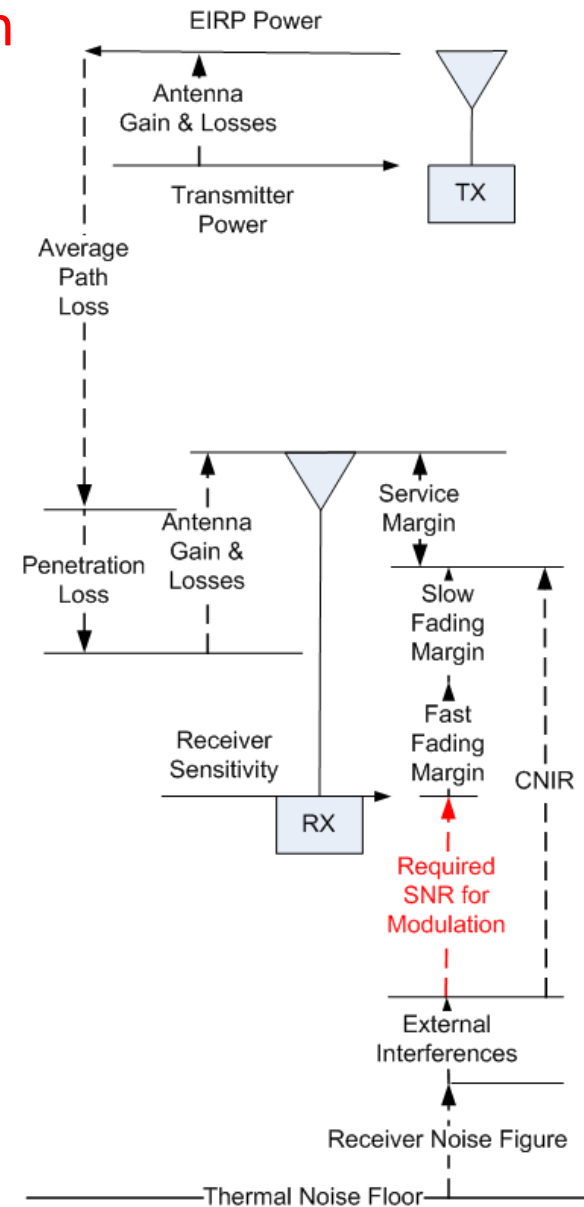

What is in a Link Budget?

Required SNR Ratio per Modulation

- User applications convey information that require a certain QoS
- Main QoS parameters are:
 - Latency (scheduling method and priority)
 - Error rate
- A QoS is associated to protocols used to convey information
- A service flow (logical interconnection) is specified for each connection of user data
- For each Error Rate there is a **Required SNR (Signal to Noise Ratio)** for each modulation scheme

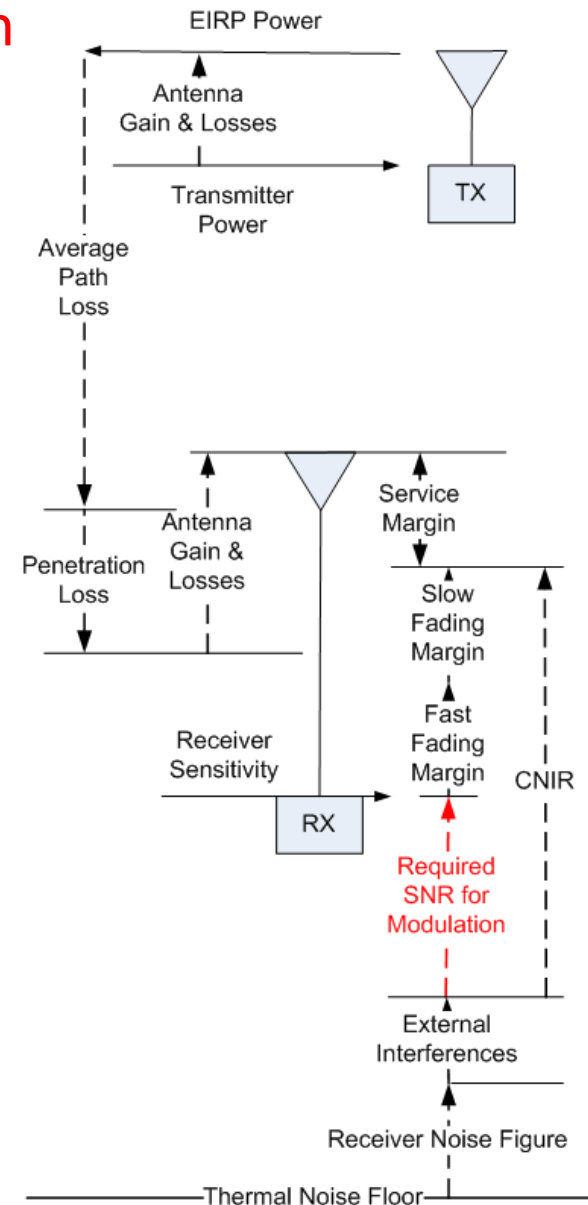

What is in a Link Budget? Fading Margins

- A receiver gets multiple copies of the transmitted signal, due to multipath propagation
- Those copies are shifted in time and attenuated in relation to each other
- A real multi-path signal is presented below
- It has slow varying (slow fading) and fast varying (fast fading) components combined

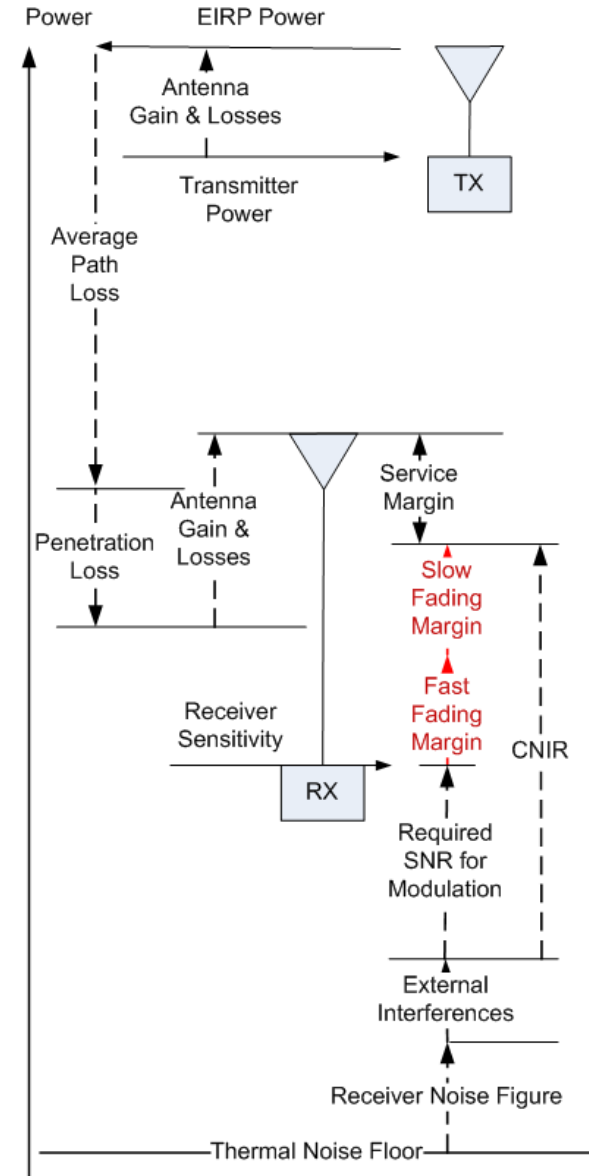
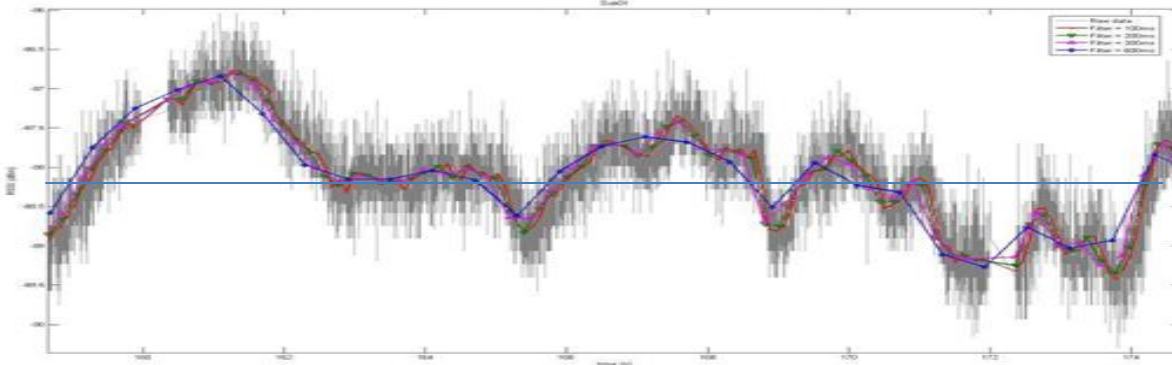
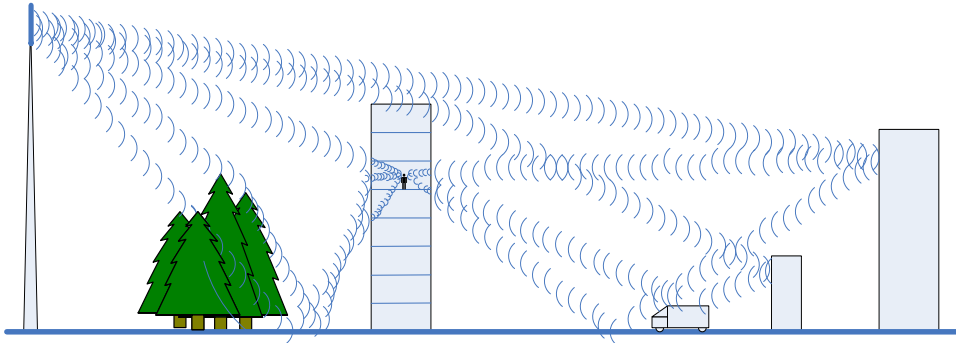

What is in a Link Budget? Fading Margins

- A received waveform is a sum of hundreds of reflected and diffracted waveforms
 - A continuous waveform can be represented by a series of sinewaves
 - If we analyze the behavior of a sinewave we can understand the behavior of a complex waveform
 - The resulting signal of combination of sinewaves is a shifted and attenuated sinewave with the same frequency as the transmitted one

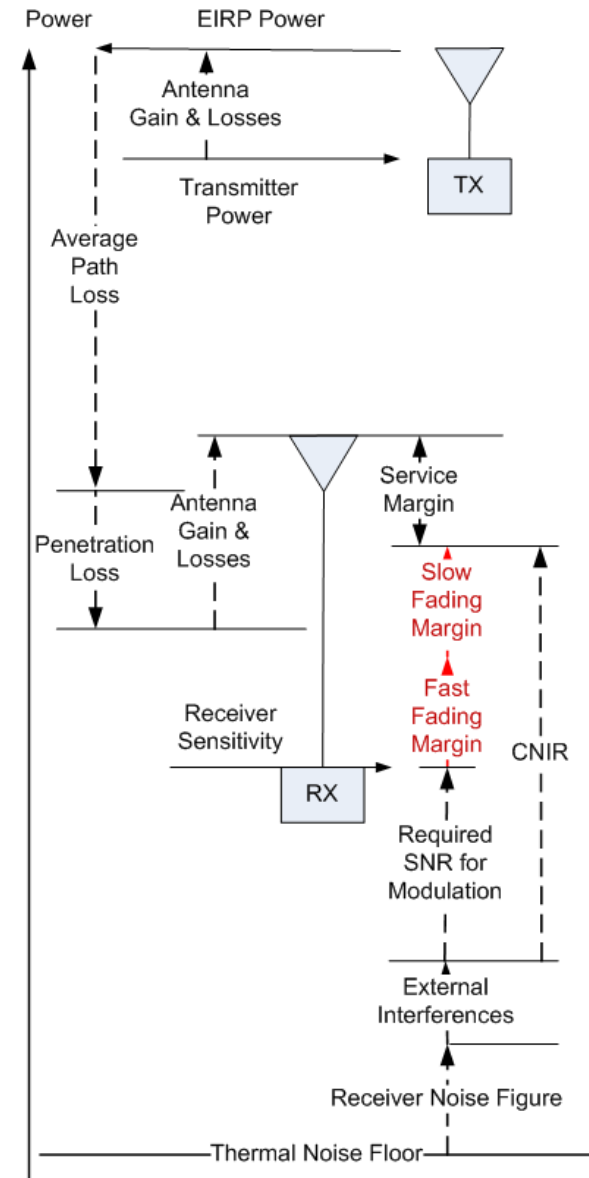
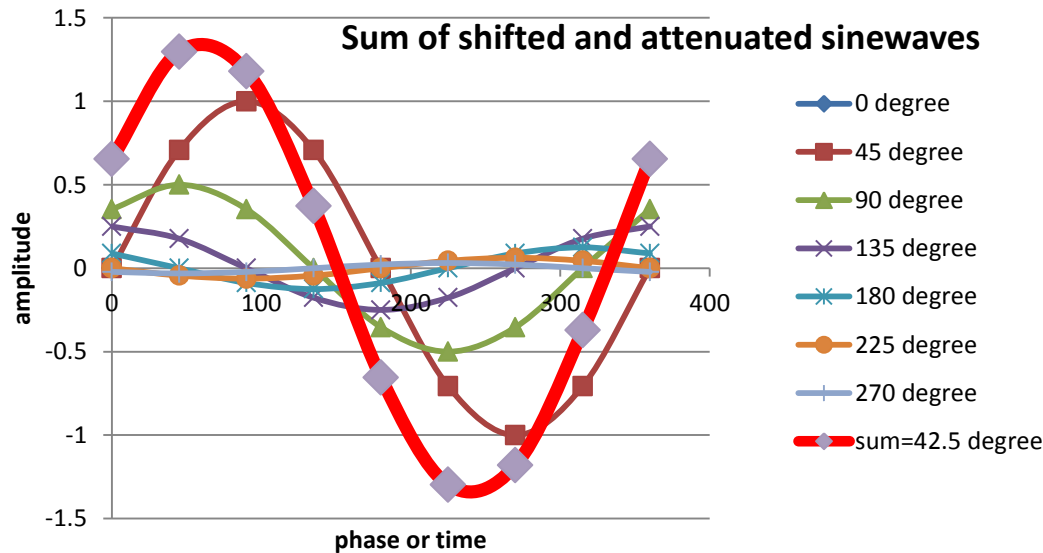

What is in a Link Budget? Fading Margins

- When there is LOS (Line-Of-Sight) between transmitter and receiver there is one predominant component
 - This signal is said to have a Gaussian distribution

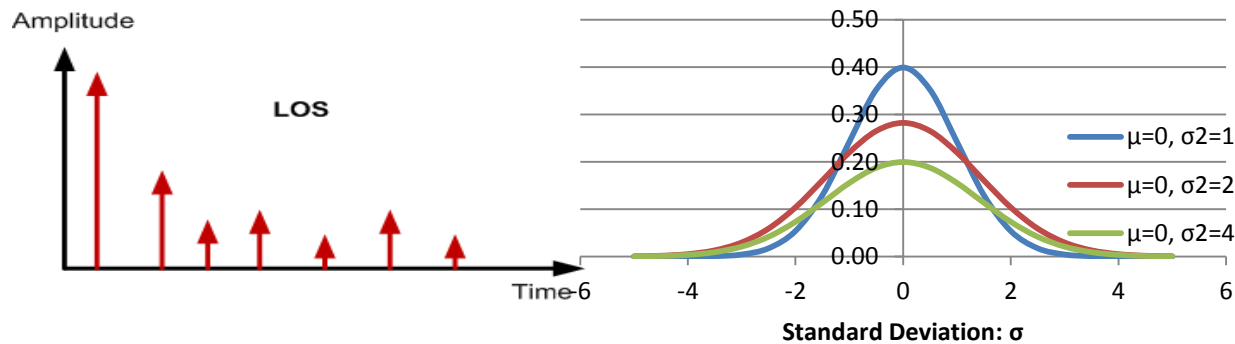

- When there is no LOS between transmitter and receiver several components have the similar amplitudes
 - This signal is said to have a Rayleigh distribution

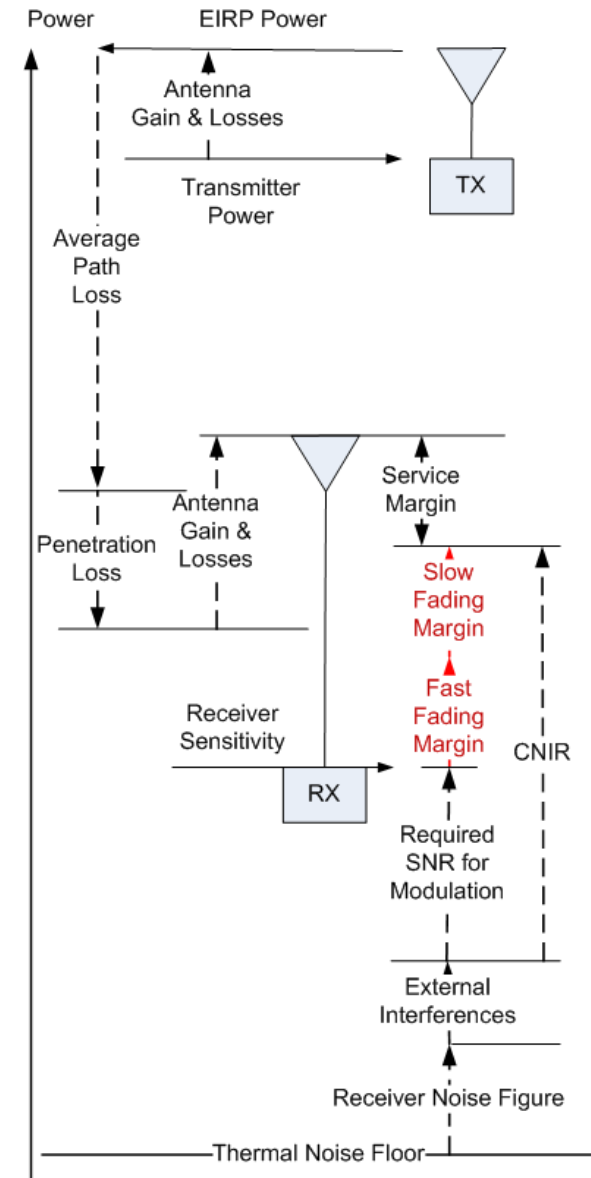
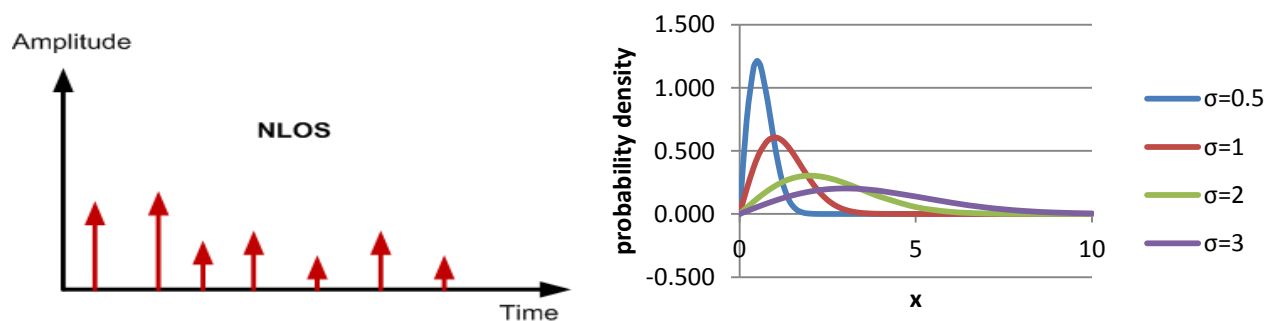

What is in a Link Budget? Fading Margins

- The average path loss is calculated over the prediction pixel area
- The slow variation, is called slow fading and is influenced by the terrain between transmitter and receiver
- The slow fading is due to the movement of the receiver in an area
- Typical values for the slow fading are between 3 and 6 dB
- These value has to be calculated based on a probability of occurrence (50 to 95 % are generally used)

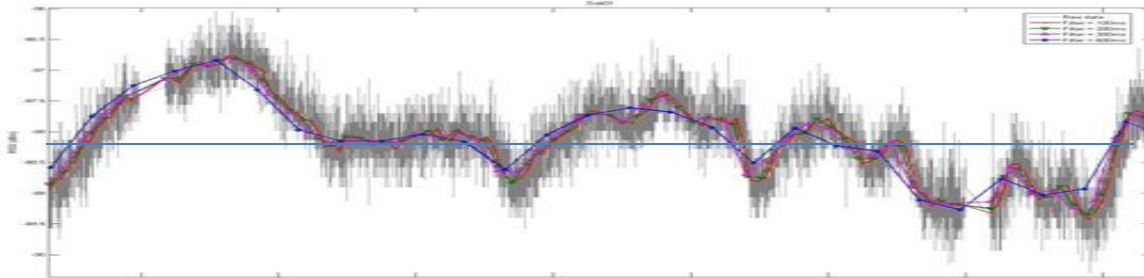

- The fast fading depends on the LOS/NLOS condition
- Typical values for the slow fading are between 4 and 9 dB
- These value has to be calculated based on a probability of occurrence (50 to 95 % are generally used)
- The CNIR requirement includes SNR and Fading Margins

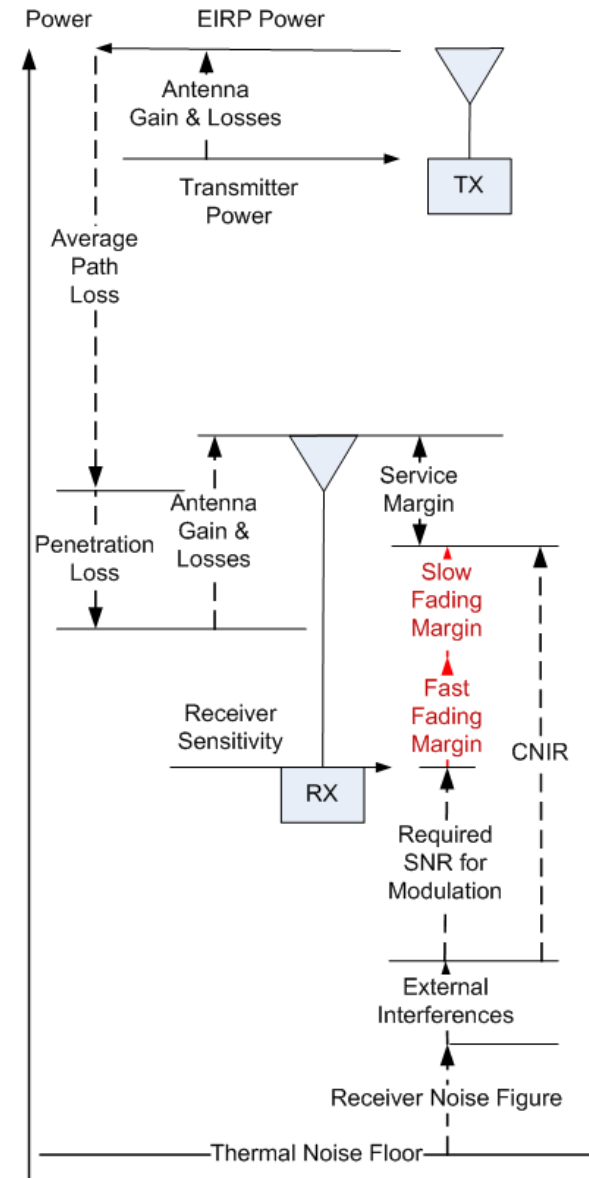

What is in a Link Budget?

CNIR (Carrier to Noise and Interference Ratio)

- Theoretical **Channel Models** are devised to model specific fading statistics, with the purpose of comparing performances
- 3GPP standardized several channel models for this purpose (all of them outdoor)

Extended ITU Models	Extended Pedestrian A (EPA)		Extended Vehicular A (EVA)		Extended Typical Urban (ETU)	
	Multipath	Relative delay (ns)	Relative power (dB)	Relative delay (ns)	Relative power (dB)	Relative power (dB)
1	0	0	0	0	0	-1
2	30	-1	30	-1.5	50	-1
3	70	-2	150	-1.4	120	-1
4	80	-3	310	-3.6	200	0
5	110	-8	710	-0.6	230	0
6	190	-17.2	1090	-9.1	500	0
7	410	-20.8	1730	-7	1600	-3
8			2510	-12	2300	-5
9				-16.9	5000	-7
Doppler Shift	Shift (Hz)		Shift (Hz)		Shift (Hz)	
1 (2 km/h)	5		5		5	
2 (30 km/h)	70		70		70	
3 (120 km/h)	300		300		300	
4 (350 km/h)	1,000		1,000		1,000	

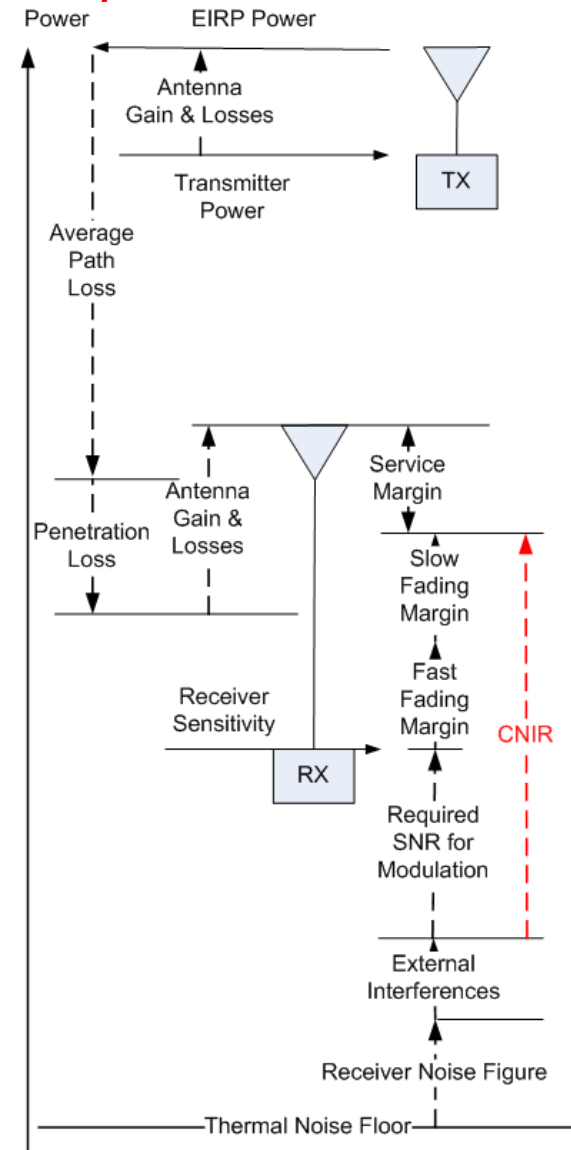

What is in a Link Budget?

CNIR (Carrier to Noise and Interference Ratio)

- In real life each prediction pixel may have a different Channel Model, which should be predicted based on parameters like:
 - LOS
 - Distance
 - Antenna height
 - Antenna type
 - Clutter factor
- Indoor fading is always of the Rayleigh type
- The channel type will then define which fading type should be applied and consequently the value of the CNIR required

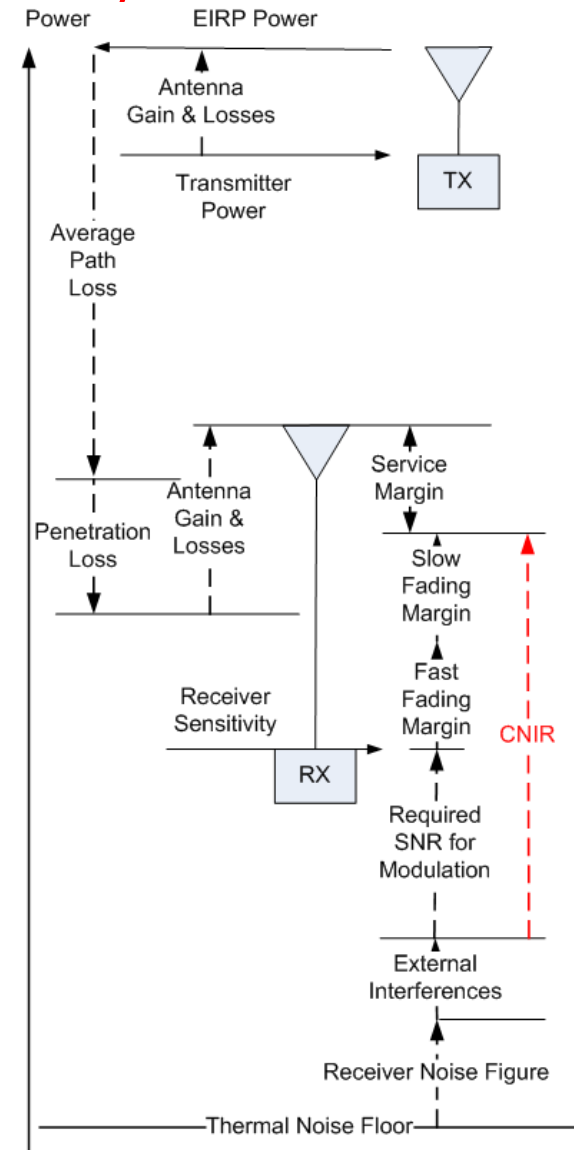

What is in a Link Budget?

- CNIR (Carrier to Noise and Interference Ratio) curves**

- A Gaussian channel requires a CINR of -5 dB for a 10^{-3} error rate
- A Rayleigh channel requires a CINR of 10 dB for a 10^{-3} error rate

SNR x BER for different modulations

AWGN channel

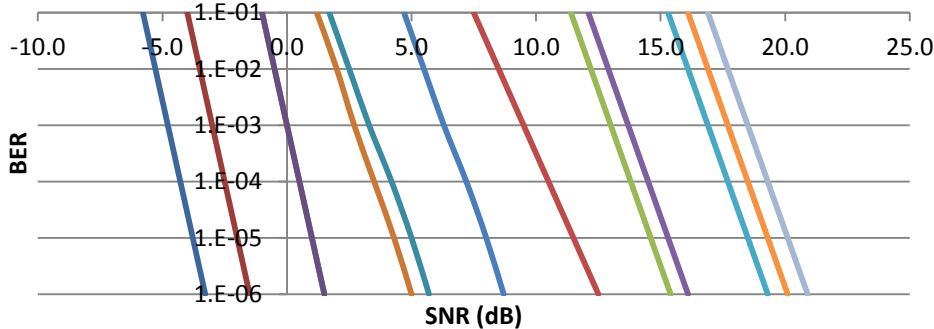

SNR x BER for different modulations

Rayleigh channel

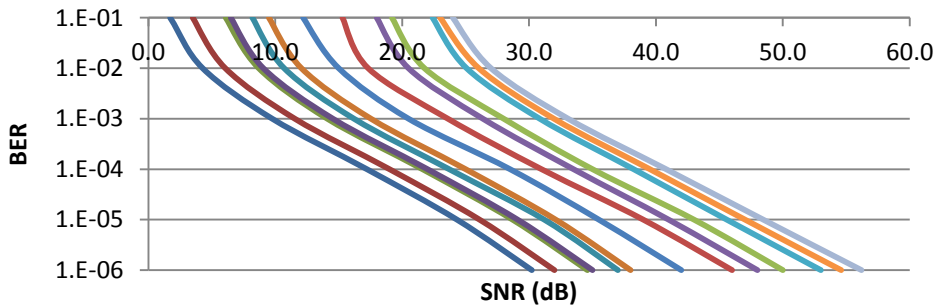

- QPSK 1/2 rep6
- QPSK 1/2 rep4
- QPSK 1/2 rep2
- BPSK 1/2
- BPSK 3/4
- QPSK 1/2
- QPSK 3/4
- 16QAM 1/2
- 16QAM 3/4
- 64QAM 1/2
- 64QAM 2/3
- 64QAM 3/4
- 64QAM 5/6

- QPSK 1/2 rep6
- QPSK 1/2 rep4
- QPSk 1/2 rep2
- BPSK 1/2
- BPSK 3/4
- QPSK 1/2
- QPSK 3/4
- 16 QAM 1/2
- 16QAM 3/4
- 64QAM 1/2
- 64QAM 2/3
- 64QAM 3/4
- 64QAM 5/6

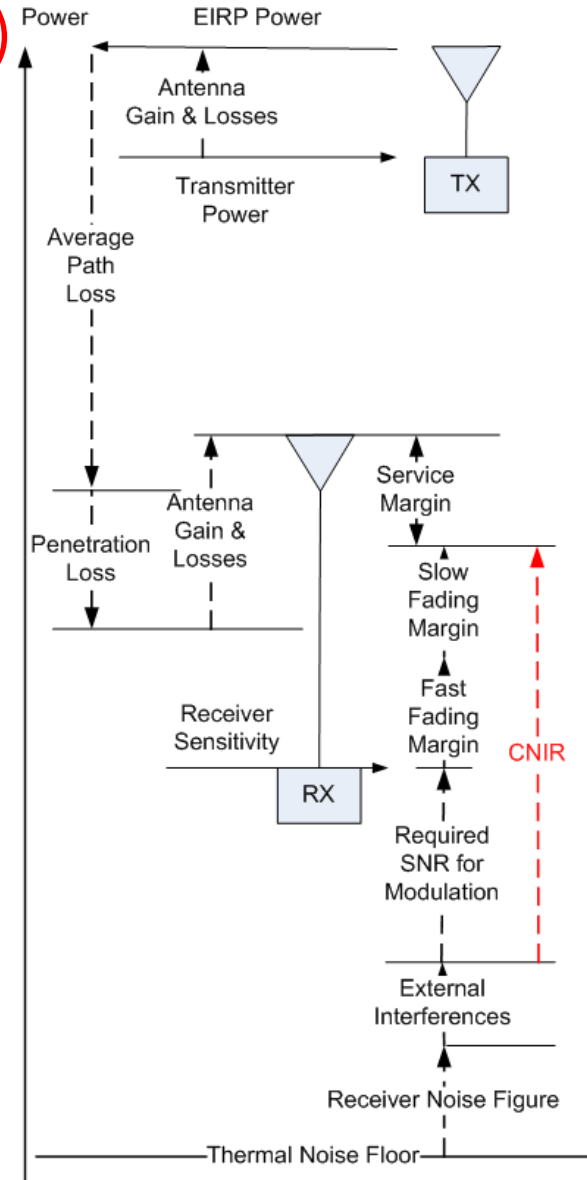

What is in a Link Budget?

Service Margin

- Service Margin
 - The difference between the power budget and the noise/interference budget is the **Service Margin**

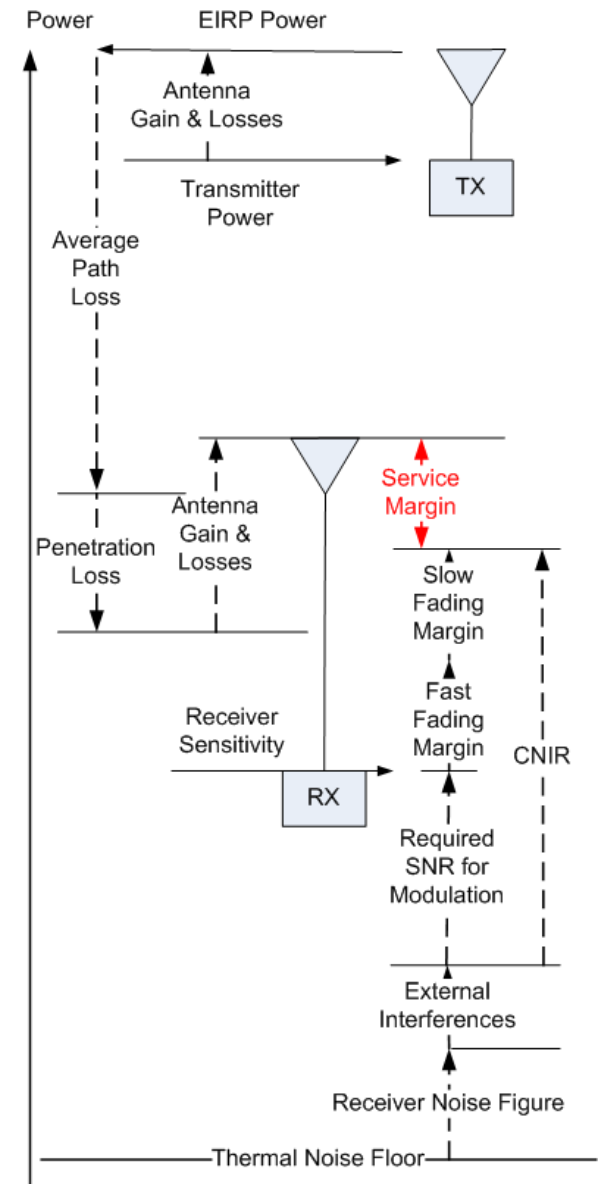

Conclusions

- Beware of excessive claims by organizations and vendors
- We should benefit from having two active standards
 - Stimulates competition
 - Offers options for different applications and costs
- WiMAX is a mature and more affordable technology
- LTE may be more convenient for 2G/3G operators with large infrastructure deployments
- Many operators are deploying both technologies, focusing different market segments
 - WiMAX: fixed and nomadic
 - LTE: mobile



Thank You!



leonhard@celplan.com

www.celplan.com

Questions?